

General Description (产品描述)

JO325D is a USB mobile device charger interface IC which implements the Qualcomm's Quick Charge 3.0 specification for adaptive voltage battery charging. It incorporates all necessary functions to add Quick Charge 3.0 capability to circuits incorporating Power Integrations' switcher ICs such as InnoSwitch™, TinySwitch™, TOPSwitch™ and other charger solutions employing traditional secondary-side feedback schemes.

JO325D supports the full output voltage range of Quick Charge 3.0, including 200 mV micro-stepped voltage levels from 3.6 V to 12 V (Class A). JO325D provides a suite of system level protection features protecting the power supply and connected Powered Device (PD) from excessive output voltages, secondary side thermal overload, and faulty power delivery while adapter is unplugged. Additionally it allows the PD to remotely shutdown the power supply through USB data lines.

JO325D automatically detects whether a connected PD is Quick Charge 3.0 or Quick Charge 2.0 capable before enabling output voltage adjustment. If a PD that is not compliant to Quick Charge 2.0 or 3.0 is detected, the HM103B disables output voltage adjustment to ensure safe operation with legacy 5 V only USB PDs.

Features(产品特性)

- Supports Quick Charge 3.0 Class A specification
- Adaptive output overvoltage protection
- Secondary over-temperature protection
- BC1.2 DCP support
- Apple DCP support
- Power consumption below 1mW at 5V output
- Supports InnoSwitch™, TinySwitch™, and TOPSwitch™

Applications(产品应用)

- Battery chargers for smart phones, tablets, netbooks, digital cameras, and bluetooth accessories
- USB power output ports such as battery banks or car chargers

Typical Application (典型应用电路)

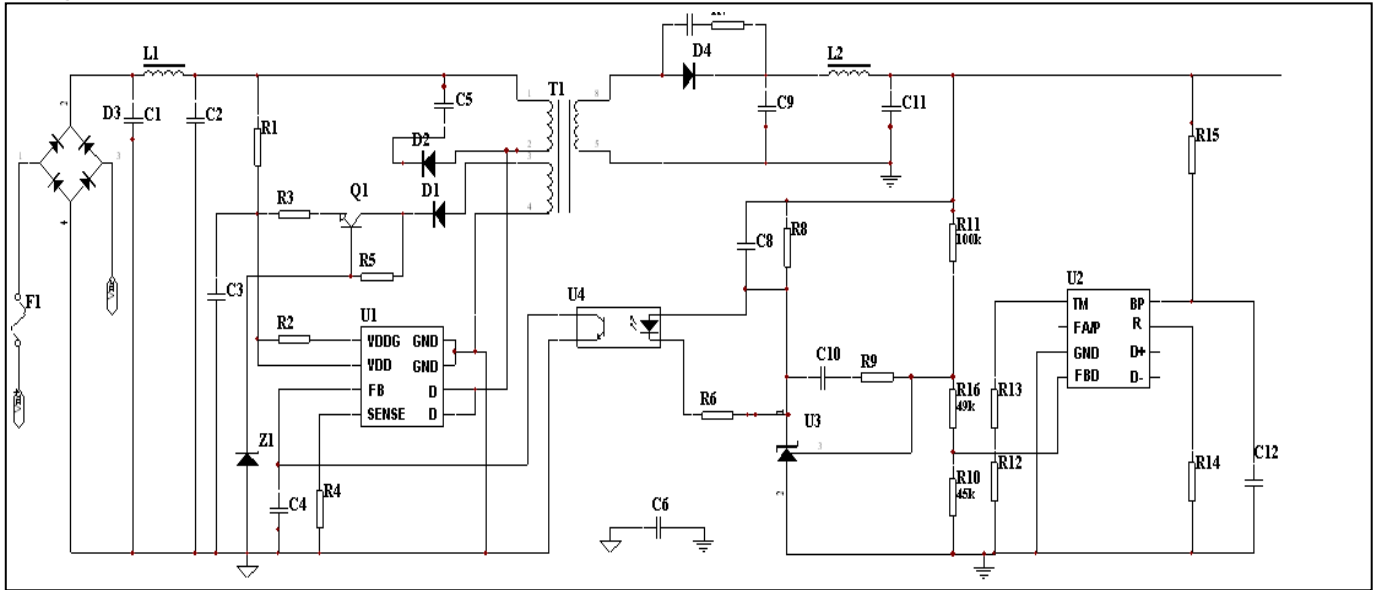

AC-DC 典型应用电路 (适配器, 旅行充)

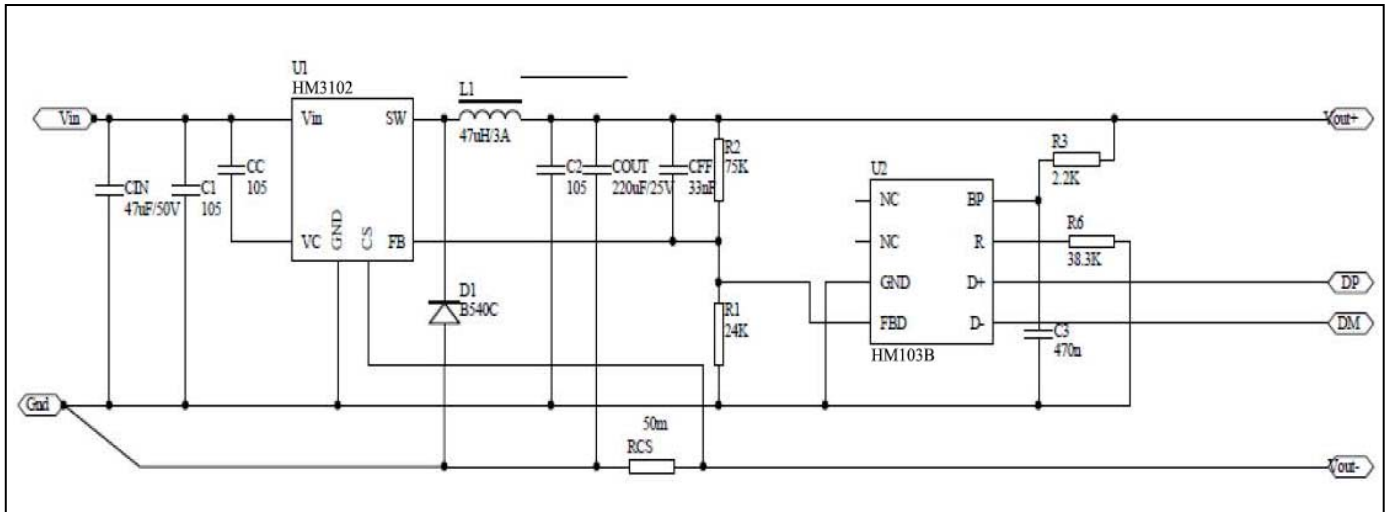

DC-DC 典型应用电路 (车充, 多口充降压型)

Pin Configuration (管脚排列)

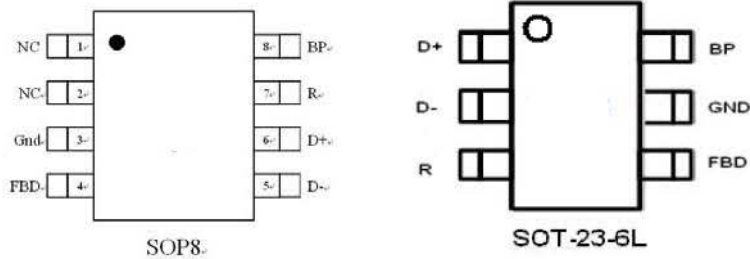

Pin Description (管脚功能描述)

NO.	Pin Name	Pin Function Description
1	NC	NOT CONNECTED (NC) Pins
2	NC	NOT CONNECTED (NC) Pins
3	GND	Ground.
4	FBD	Feedback loop drive output and monitors output voltage.
5	D-	USB D- data line input.
6	D+	USB D+ data line input.
7	R	Provides reference current and output voltage range.
8	BP	Connection an external bypass capacitor for the internally generated supply voltage.

Functional Block Diagram (功能框图)

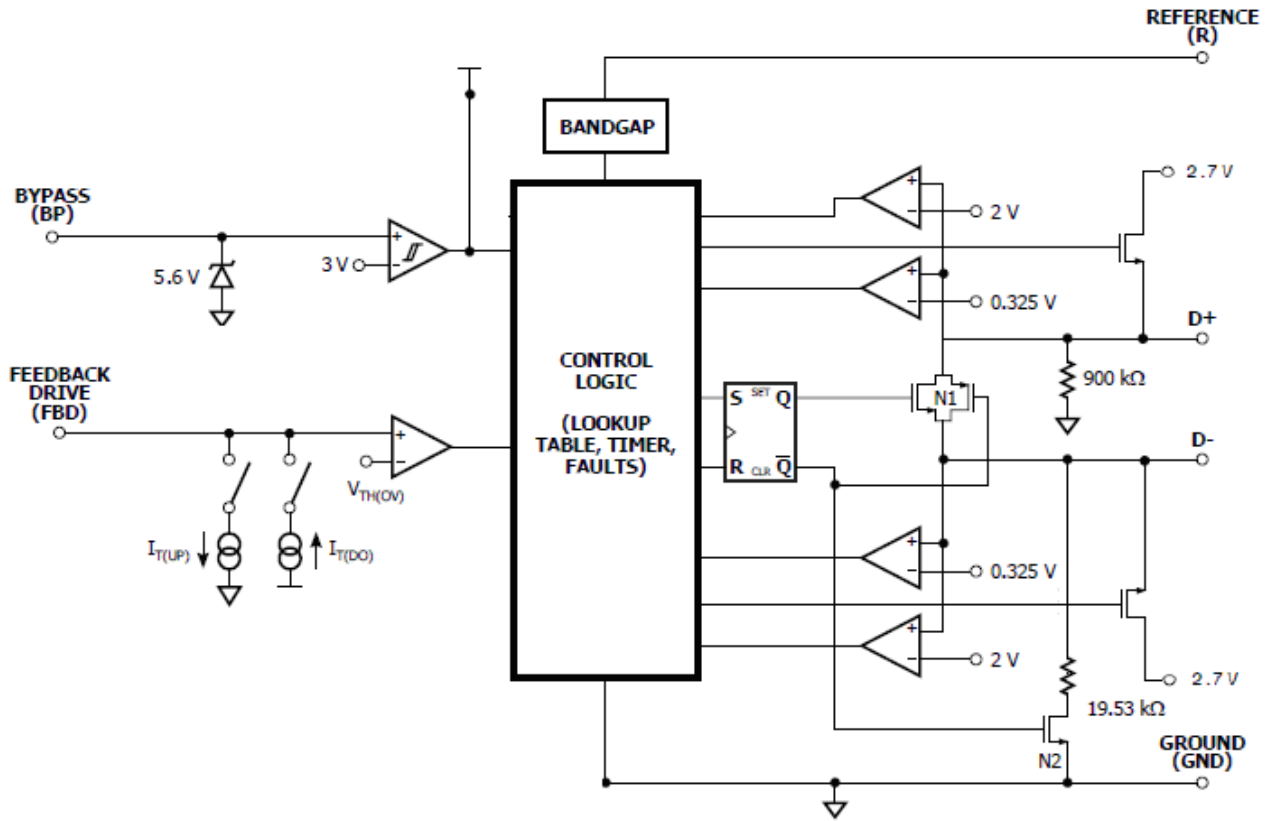

Ordering Information (订货信息)

Absolute Maximum Ratings(最大额定参数)

Symbol	Parameter	Maximum	Units
V_{BP}	BYPASS Pin Voltage	5.6	V
V_R	REFERENCE Pin Voltage	5	V
V_{FBD}	FBD Pin Voltage	$V_{BP}+0.7V$	V
$V_{D+/D-}$	D+/D- Pin Voltage	5	V
I_{BP}	BYPASS Pin Current	25	mA
$I_{D+/D-}$	D+/D- Pin Current	1	mA

Recommended Operating Conditions(推荐工作条件)

Symbol	Parameter	Maximum	Units
T_J	Operating Junction Temperature	-20 to 125	°C
T_A	Operating Ambient Temperature	-20 to 85	°C
T_s	Storage Temperature	-65 to 150	°C
	Lead Temperature (less than 15 seconds)	260	°C

Electrical Characteristics(电气参数)

($V_{CC}=5V$; $T_J=25^\circ C$ unless otherwise specified)

Symbol	Test Conditions	Min	Typ	Max	Unit
V_{BP}		4	5		V
$V_{BP}(\text{reset})$		3.8			V
I_{BPSC}	$V_{BP} = 4.3 V, R_{REF} = 33 k\Omega, T_J = 25^\circ C$				μA
$V_{BP}(\text{SHUTDOWN})$	$I_{BP}=8mA$				V
V_R	$R_{REF}=33K\Omega$				V
$V_{DAT(REF)}$			0.325		V
$V_{SEL(REF)}$			2		
$T_{DAT(SHORT)}$	$V_{OUT} \geq 0.8V$			20	ms
$T_{GLITCH(BC)DONE}$		1000		1500	ms

$T_{\text{GLITCH(DM)LOW}}$		1			ms	
$T_{\text{GLITCH(V)CHANGE}}$		20	40	60	ms	
$T_{\text{GLITCH(CONT)CHANGE}}$		100		200	μs	
$R_{\text{DAT(LKG)}}$	$V_{\text{BP}}=4.3\text{V}$, $V_{\text{D+}}=0.5\text{-}3.6\text{V}$, N1 is off	300		1500	$\text{K}\Omega$	
$R_{\text{DM(DWN)}}$		14.25	19.53	24.5	$\text{K}\Omega$	
$R_{\text{DS(N1)}}$	$V_{\text{BP}}=4.3\text{V}$, $V_{\text{D+}}\leq 3.6\text{V}$, $I_{\text{DRAIN}}=200\mu\text{A}$		20	40	Ω	
$I_{\text{T(UP)}}$			2		μA	
$I_{\text{T(DO)}}$			2		μA	
$V_{\text{TH(OV)}}$	QC2.0 Mode ClassA/ClassB	$I_{\text{(UP)}}=0$ (5V)	1.44	1.52	1.60	V
		$I_{\text{(UP)}}=40\mu\text{A}$ (9V)	1.60	1.72	1.84	
		$I_{\text{(UP)}}=70\mu\text{A}$ (12V)	1.74	1.87	2.00	
	QC3.0 Mode Continuous Mode	$R_{\text{REF}}=33\text{K}$ ClassA	1.74	1.87	2.00	

Functional Description (功能描述)

HM103B is a USB high-voltage dedicated charging port (HVDCP) interface IC for the Quick Charge 3.0 specification. It incorporates all necessary functions to add Quick Charge 3.0 capability to Power Integrations' switcher ICs such as InnoSwitch, TinySwitch, and TOPSwitch.

HM103B also supports other solutions with traditional secondary-side feedback schemes such as J O 653 for instance.

HM103B supports the full output range of Quick Charge 3.0 Class A (3.6 V to 12 V) and its subset Quick Charge 2.0 Class A (5 V, 9 V, or 12 V). It automatically detects either Quick Charge 3.0 or Quick Charge 2.0 capable powered devices (PD) or legacy PDs compliant with USB Battery Charging Specification revision 1.2 and only enables output voltage adjustments accordingly.

Shunt Regulator

The internal shunt regulator clamps the BYPASS pin at 5.2 V when current is provided through an external resistor. This facilitates powering HM103B externally over a wide output voltage range of 3.6 V to 20 V. Recommended values are $R_{BP} = 2.2 \text{ k}\Omega \pm 1\%$ and $CBP = 470 \text{ nF}$.

BYPASS Pin Undervoltage

The BYPASS pin undervoltage circuitry resets the HM103B when the BYPASS pin voltage drops below 2.9 V. Once the BYPASS pin voltage drops below 2.9 V it must rise back to 3.1 V to commence correct operation.

Reference and Output Voltage Range Selection Input

Resistor R_{REF} at the REFERENCE pin is connected to an internal band gap reference and provides an accurate reference current for internal timing circuits. Resistor R_{REF} is furthermore used to select the output voltage range. $R_{REF} = 33 \text{ k}\Omega \pm 1\%$ selects Class A (12 V maximum output voltage)

Portable Device (PD)		SE 0163	
D+	D-	Power Supply Output	Note
0.6 V	0.6 V	12 V	Class A
3.3 V	0.6 V	9 V	Class A
0.6 V	3.3 V	Continuous Mode	Class A/B with $\pm 0.2 \text{ V}$ step size
0.6 V	GND	5 V	Default mode

Feedback Loop Drive

HM103B sets the respective output power supply voltage regulation point by directly driving the reference input of the power supply control loop error amplifier through an internal current sink $I_{T(UP)}$ and source $I_{T(DO)}$

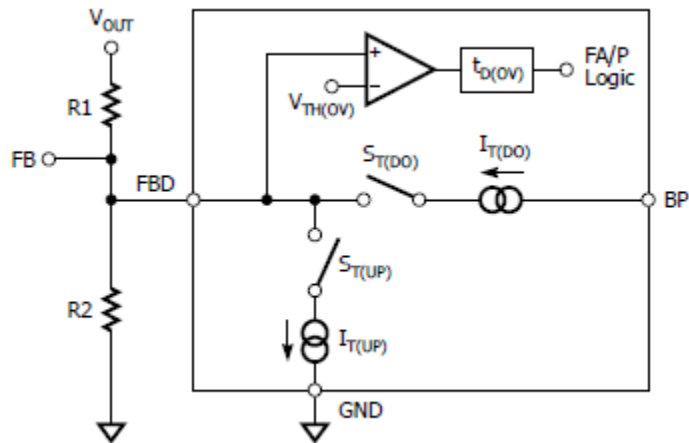

In default mode with a 5 V output both, the internal current source and current sink are off. To meet the output voltage step size requirement of ± 0.2 V in Quick Charge 3.0 continuous mode, the mandatory value for the upper resistor in the output sensing voltage divider is $R1 = 70.0 \text{ k}\Omega \pm 1\%$. For a FEEDBACK pin reference voltage of 1.25 V for instance used by Power Integrations' InnoSwitch switcher IC the resulting value for $R2 = 23.0 \text{ k}\Omega \pm 1\%$ to set the default output voltage to 5 V.

HM103B can also interface with power supply control loop reference voltages lower than 1.265 V by adding resistor R3.

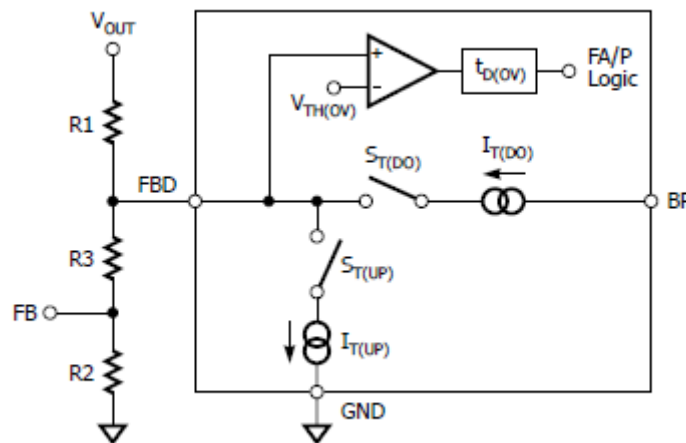

The output voltage is determined at default 5 V output as follows:

$$V_{OUT} = \frac{V_{FB} \times R1}{R2} \times \frac{V_{FB} \times (R2 + R3)}{R2}$$

Outline Drawing For SOP-8

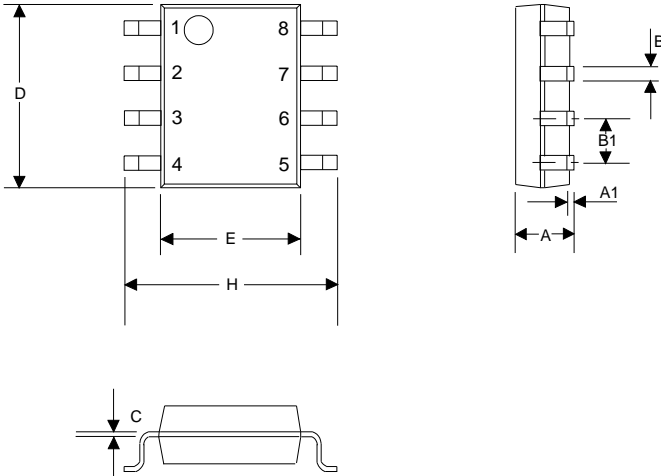

DIMENSIONS				
DIM ^N	INCHES		MM	
	MIN	MAX	MIN	MAX
A	0.0532	0.0688	1.35	1.75
A1	0.0040	0.0098	0.10	0.25
B	0.0130	0.0200	0.33	0.51
B1	0.050 BSC		1.27 BSC	
C	0.0075	0.0098	0.19	0.25
D	0.1890	0.1968	4.80	5.00
H	0.2284	0.2440	5.80	6.20
E	0.1497	0.1574	3.80	4.00