

Features

- Wide 3.6V to 18V Input Voltage Range
- Output Adjustable from 1.222V to 16V
- Maximum Duty Cycle 100%
- Minimum Drop Out 0.6V
- Fixed 380KHz Switching Frequency
- 2A Constant Output Current Capability
- Internal Optimize Power MOSFET
- High efficiency
- Excellent line and load regulation
- TTL shutdown capability
- EN pin with hysteresis function
- Built in thermal shutdown function
- Built in current limit function
- Built in output short protection function
- Available in SOP8 package

Applications

- LCD Monitor and LCD TV
- Digital Photo Frame
- Set-up Box
- ADSL Modem
- Telecom / Networking Equipment

General Description

The HM1410 is a 380KHz fixed frequency PWM buck (step-down) DC/DC converter, capable of driving a 2A load with high efficiency, low ripple and excellent line and load regulation. Requiring a minimum number of external components, the regulator is simple to use and include internal frequency compensation and a fixed-frequency oscillator.

The PWM control circuit is able to adjust the duty ratio linearly from 0 to 100%. An enable function, an over current protection function is built inside. When short protection function happens, the operation frequency will be reduced from 380KHz to 80KHz. An internal compensation block is built in to minimize external component count.



SOIC-8

Figure1. Package Type of HM1410

Pin Configurations

NC	1	8	NC
VIN	2	7	EN
HM1410			
SW	3	6	NC
GND	4	5	FB

Figure2. Pin Configuration of HM1410 (Top View)

Pin Number	Pin Name	Description
1,6,8	NC	No Connected.
2	VIN	Supply Voltage Input Pin. HM1410 operates from a 3.6V to 18V DC voltage. Bypass Vin to GND with a suitably large capacitor to eliminate noise on the input.
3	SW	Power Switch Output Pin (SW). Output is the switch node that supplies power to the output.
4	GND	Ground Pin. Care must be taken in layout. This pin should be placed outside of the Schottky Diode to output capacitor ground path to prevent switching current spikes from inducing voltage noise into HM1410.
5	FB	Feedback Pin (FB). Through an external resistor divider network, Feedback senses the output voltage and regulates it. The feedback threshold voltage is 1.222V.
7	EN	Enable Pin. Drive EN pin low to turn off the device, drive it high to turn it on. Floating is default high.

Function Block

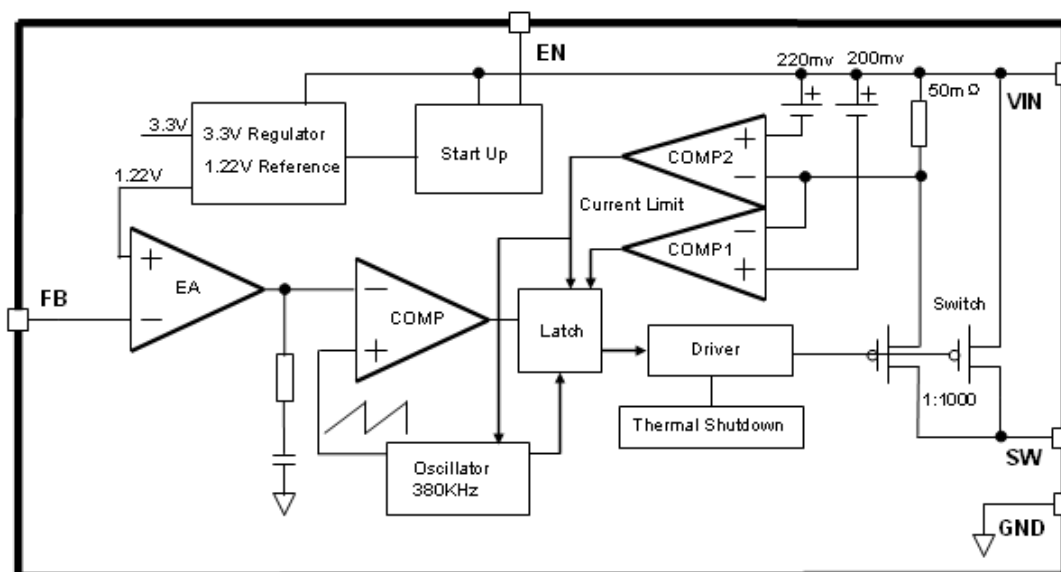

Figure3. Function Block Diagram of HM1410

Typical Application Circuit

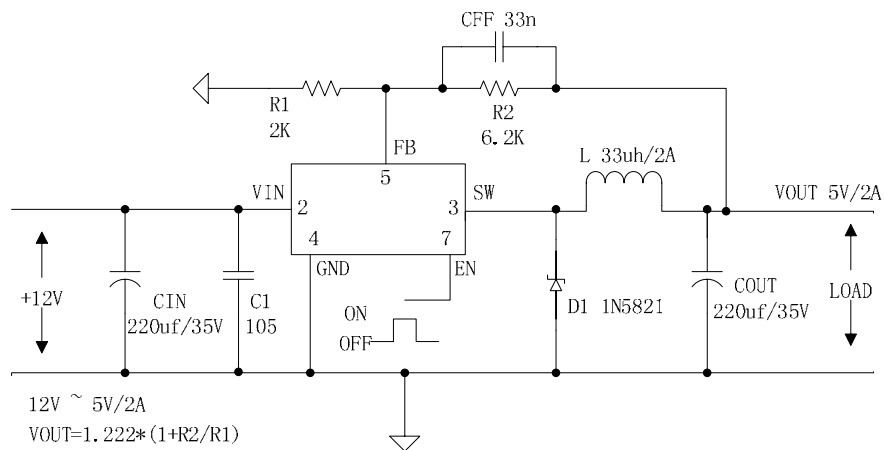
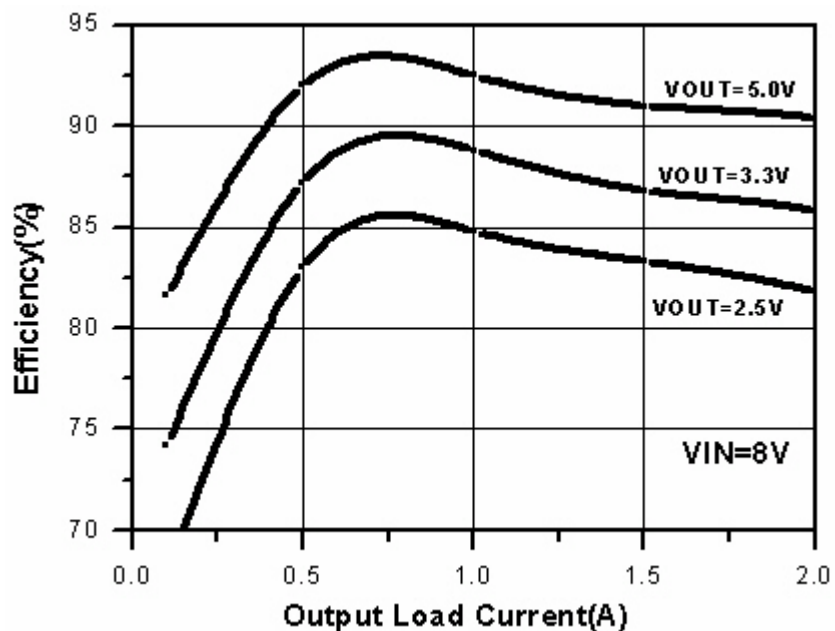

Figure4. HM1410 Typical Application Circuit

System Efficiency Curve



Ordering Information

Package	Temperature Range	Part Number	Marking ID	Packing Type
		Lead Free	Lead Free	
		HM1410	HM1410	Tube
		HM1410S	HM1410	Tape & Reel

Absolute Maximum Ratings (Note1)

Parameter	Symbol	Value	Unit
Input Voltage	V_{in}	-0.3 to 20	V
Feedback Pin Voltage	V_{FB}	-0.3 to V_{in}	V
EN Pin Voltage	V_{EN}	-0.3 to V_{in}	V
Output Switch Pin Voltage	V_{Output}	-0.3 to V_{in}	V
Power Dissipation	P_D	Internally limited	mW
Thermal Resistance (SOP8) (Junction to Ambient, No Heatsink, Free Air)	R_{JA}	100	°C/W
Operating Junction Temperature	T_J	-40 to 125	°C
Storage Temperature	T_{STG}	-65 to 150	°C
Lead Temperature (Soldering, 10 sec)	T_{LEAD}	260	°C
ESD (HBM)		2000	V

Note1: Stresses greater than those listed under Maximum Ratings may cause permanent damage to the device. This is a stress rating only and functional operation of the device at these or any other conditions above those indicated in the operation is not implied. Exposure to absolute maximum rating conditions for extended periods may affect reliability.

2A 380KHz 18V Buck DC to DC Converter

H M 1 4 1 0

HM1410 Electrical Characteristics

$T_a = 25$; unless otherwise specified.

Symbol	Parameter	Test Condition	Min.	Typ.	Max.	Unit
<i>System parameters test circuit figure4</i>						
VFB	Feedback Voltage	$V_{in} = 7V \text{ to } 18V, V_{out}=5V$ $I_{load}=0.2A \text{ to } 2A$	1.186	1.222	1.258	V
Efficiency	η	$V_{in}=12V, V_{out}=5V$ $I_{out}=2A$	-	89	-	%

Electrical Characteristics (DC Parameters)

$V_{in} = 12V, GND=0V, V_{in}$ & GND parallel connect a 220uf/50V capacitor; $I_{out}=500mA, T_a = 25$; the others floating unless otherwise specified.

Parameters	Symbol	Test Condition	Min.	Typ.	Max.	Unit
Input operation voltage	V_{in}		3.6		18	V
Shutdown Supply Current	I_{STBY}	$V_{EN}=0V$		60	200	uA
Quiescent Supply Current	I_q	$V_{EN} = 2V,$ $V_{FB} = V_{in}$		3	5	mA
Oscillator Frequency	F_{osc}		323	380	437	Khz
Switch Current Limit	I_L	$V_{FB} = 0$		4		A
EN Pin Threshold	V_{EN}	High (Regulator ON) Low (Regulator OFF)		1.4 0.8		V
EN Pin Input Leakage Current	I_H	$V_{EN} = 2V$ (ON)		1	15	uA
	I_L	$V_{EN} = 0V$ (OFF)		1	15	uA
Max. Duty Cycle	D_{MAX}	$V_{FB}=0V$		100		%

4C'5: 2MJ | '3: X'DwemlF E 'vq'F E 'E qpxgt vgt '.....'J O 3 6 3 2''

Package Information

SOP8 Package Mechanical Dimensions

