

1.4MHz, 1.2A, 24V High Efficiency Step-Down Converter in SOT23-6

DESCRIPTION

The HM2359 is a wide input range, high-efficiency, high frequency DC-to-DC step-down switching regulator, capable of delivering up to 1.2A of output current. With a fixed switching frequency of 1.4MHz, this current mode PWM controlled converter allows the use of small external components, such as ceramic input and output caps, as well as small inductors, while still providing low output ripples. Together with the tiny package HM2359 is in, without external compensation components, it is an ideal solution for system designer with stringent board space requirements. HM2359 also employs a proprietary control scheme that switches the device into a power save mode during light load, thereby extending the range of high efficiency operation.

HM2359 is available SOT23-6 Packages.

APPLICATIONS

- Set top boxes
- Security Surveillance systems
- LED drivers

FEATURES

- **Wide Input Operating Range from 4.5V to 24V**
- **High Efficiency:**
 - Up to 94%
- **Capable of Delivering 1.2A**
- **1.4MHz Switching frequency**
- **No External Compensation Needed**
- Current Mode control
- Logic Control Shutdown
- Thermal shutdown and UVLO
- Available in SOT23-6 Package

ORDERING INFORMATION

PART	PACKAGE PIN	TOP MARK
HM2359	SOT23-6	CAYW └── Date Code └── Product Number

TYPICAL APPLICATION

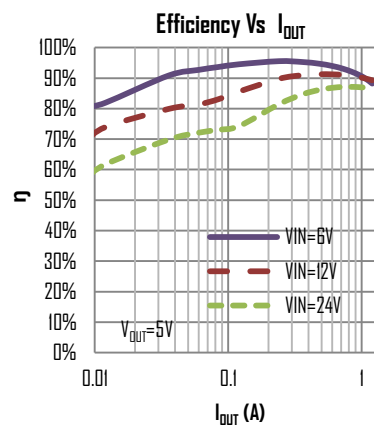
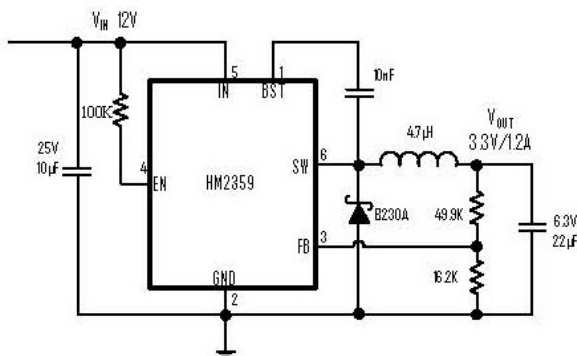

PIN CONFIGURATION

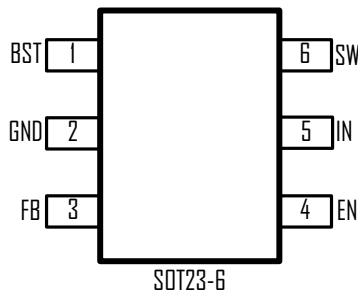

ABSOLUTE MAXIMUM RATINGS

(Note: Exceeding these limits may damage the device. Exposure to absolute maximum rating conditions for long periods may affect device reliability.)

IN Voltage.....	-0.3V to 26V
SW, EN Voltage.....	-0.3V to VIN+0.3V
BST Voltage.....	-0.3V to SW+6V
FB Voltage.....	-0.3V to 6V
SW to ground current	Internally limited
Operating Temperature Range	-40°C to 85°C
Storage Temperature Range	-55°C to 150°C
Thermal Resistance	θ_{JA} θ_{JC}
SOT23-6.....	220.....110.....°C/W

ELECTRICAL CHARACTERISTICS

(VIN = 12V, unless otherwise specified. Typical values are at TA = 25°C.)

PARAMETER	CONDITIONS	MIN	TYP	MAX	UNITS
Input Voltage Range		4.2		24	V
Input UVLO	Rising, Hysteresis=140mV		3.55		V
Input OVP	Rising, Hysteresis=1.3V		26		V
Input Supply Current	VFB = 0.9V		0.6		mA
Input Shutdown Current			6		µA
FB Feedback Voltage		0.79	0.81	0.83	V
FB Input Current			0.01		µA
Switching Frequency		1.0	1.4	1.8	MHz
FoldBack Frequency	VFB = 0V		100		KHz
High side Switch On Resistance	ISW = 200mA		250	500	mΩ
High side Switch Current Limit	VIN=12V, VOUT=5V	1.5	2		A
SW Leakage Current	VIN=12V, VSW=0, EN= GND			10	µA
EN Input Current				1	µA
EN Input Low Voltage		1	1.5	3	V
Thermal Shutdown	Hysteresis=40°C		150		°C

PIN DESCRIPTION

PIN #	NAME	DESCRIPTION
1	BST	Bootstrap pin. Connect a 10nF capacitor from this pin to SW
2	GND	Ground
3	FB	Feedback Input. Connect an external resistor divider from the output to FB and GND to set VOUT
4	EN	Enable pin for the IC. Drive this pin to high to enable the part, low to disable.
5	IN	Supply Voltage. Bypass with a 10µF ceramic capacitor to GND
6	SW	Inductor Connection. Connect an inductor Between SW and the regulator output.

TYPICAL CHARACTERISTICS

(Typical values are at TA = 25°C unless otherwise specified.)

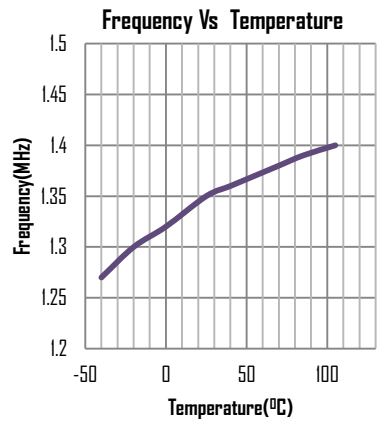
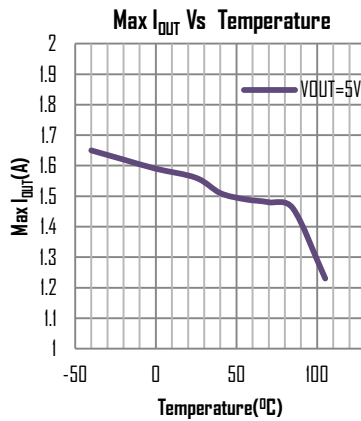
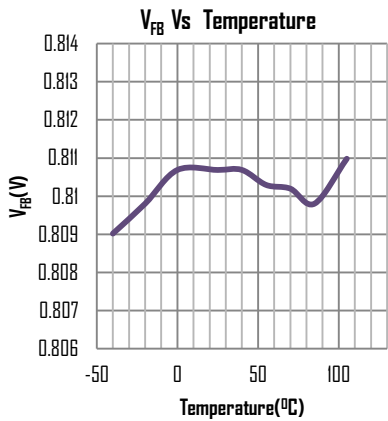
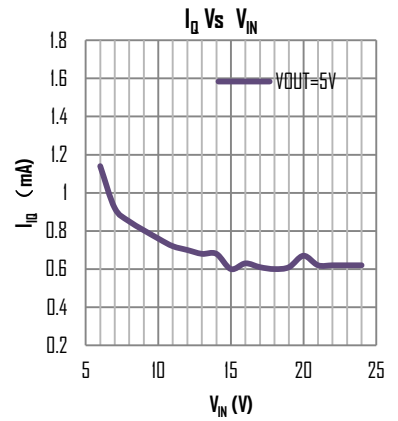
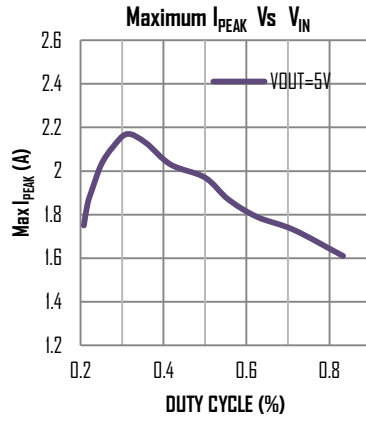
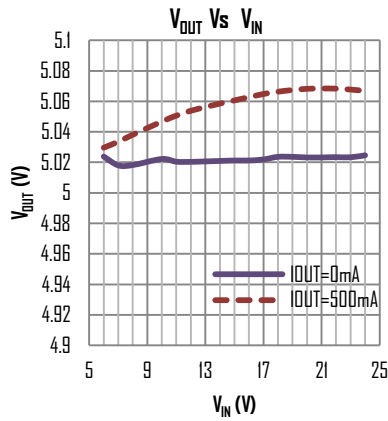
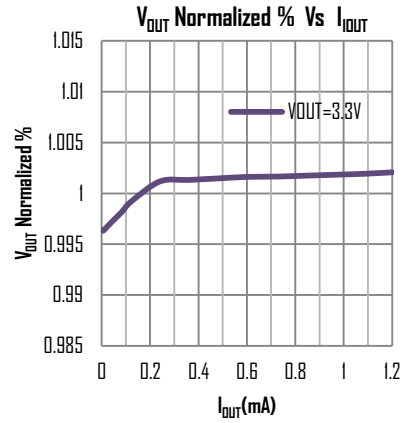
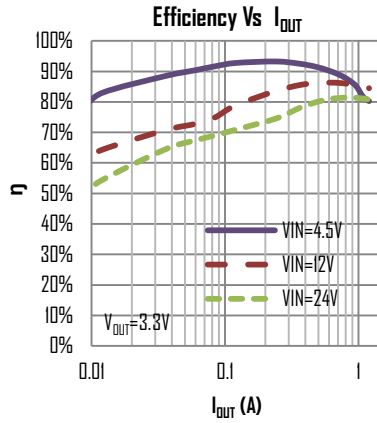
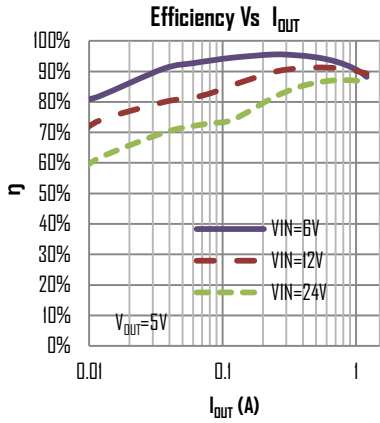

TYPICAL CHARACTERISTICS

(Typical values are at $T_A = 25^{\circ}\text{C}$ unless otherwise specified.)

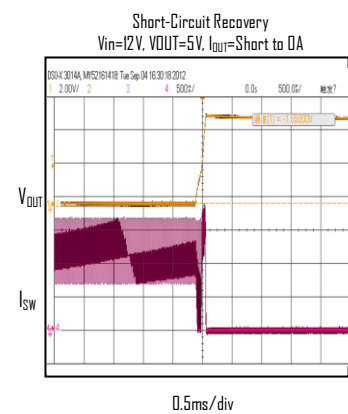
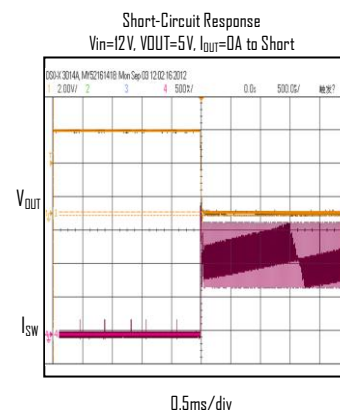
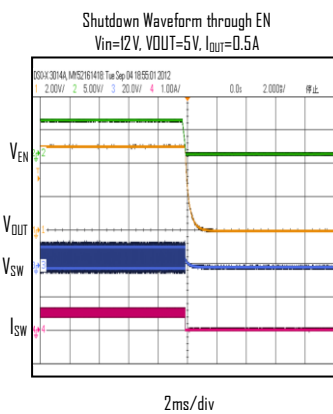
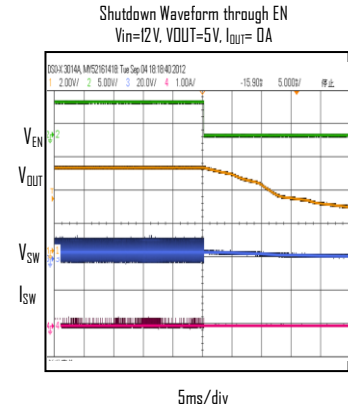
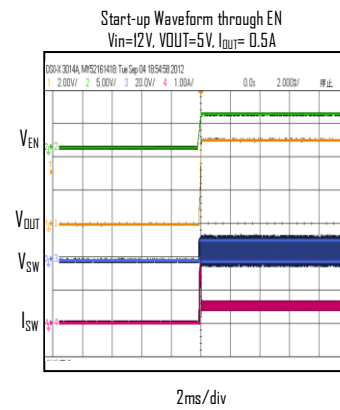
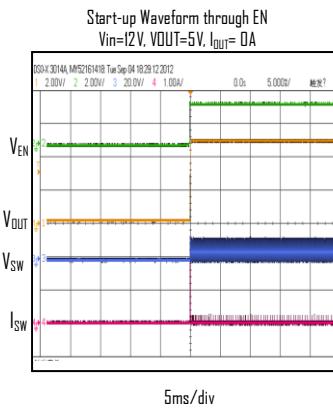
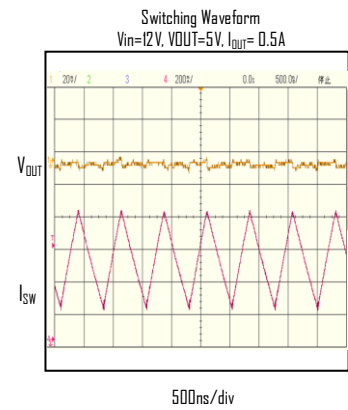
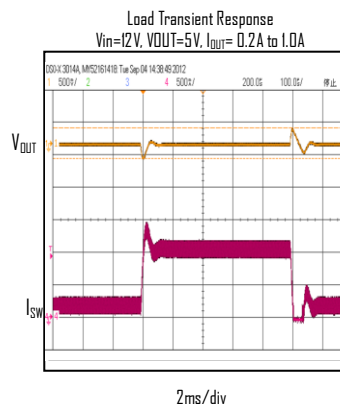
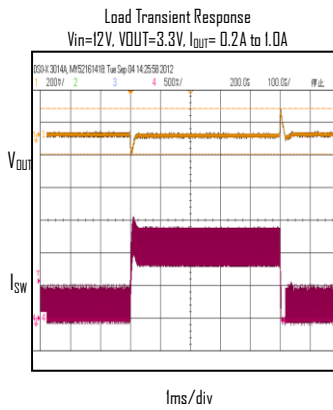

FUNCTIONAL DESCRIPTIONS

Loop Operation

The HM2359 is a wide input range, high-efficiency, DC-to-DC step-down switching regulator, capable of delivering up to 1.2A of output current, integrated with a 250mΩ high-side MOSFET. It uses a PWM current-mode control scheme. An error amplifier integrates error between the FB signal and the internal reference voltage. The output of the integrator is then compared to the sum of a current-sense signal and the slope compensation ramp. This operation generates a PWM signal that modulates the duty cycle of the power MOSFETs to achieve regulation for output voltage.

Light Load Operation

Traditionally, a fixed constant frequency PWM DC-DC regulator always switches even when the output load is small. When energy is shuffling back and forth through the power MOSFETs, power is lost due to the finite RDSONs of the MOSFETs and parasitic capacitances. At light load, this loss is prominent and efficiency is therefore very low. HM2359 employs a proprietary control scheme that improves efficiency in this situation by enabling the device into a power save mode during light load, thereby extending the range of high efficiency operation.

BLOCK DIAGRAM

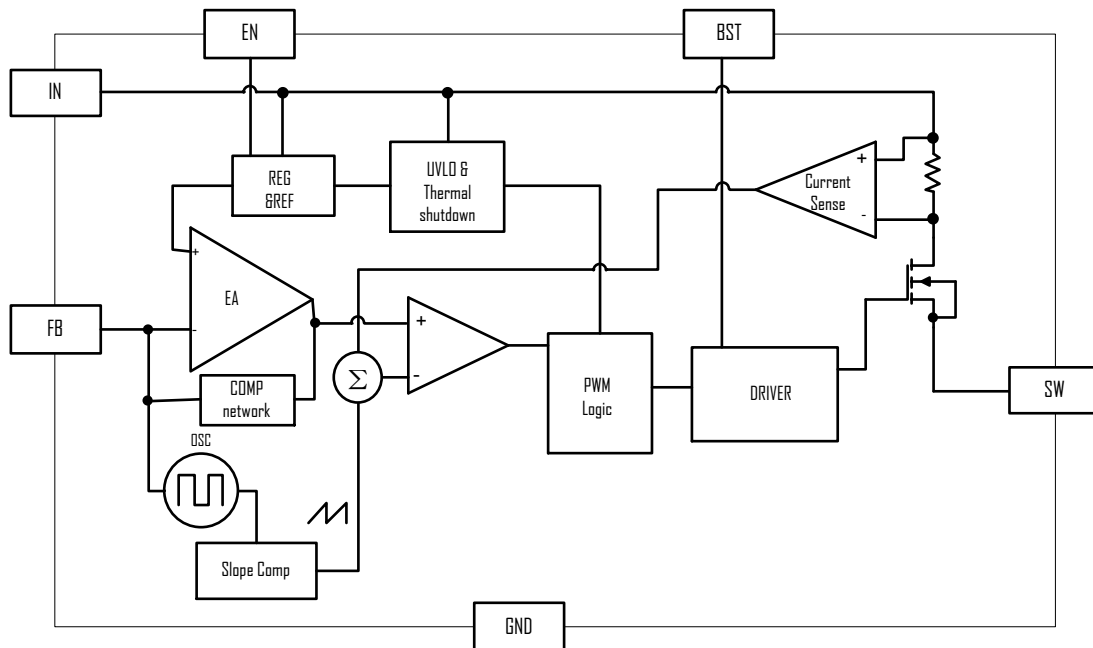

APPLICATION INFORMATION

Setting Output Voltages

Output voltages are set by external resistors. The FB threshold is 0.81V.

$$R_{TOP} = R_{BOTTOM} \times [(V_{OUT} / 0.81) - 1]$$

Inductor Selection

The peak-to-peak ripple is limited to 30% of the maximum output current. This places the peak current far enough from the minimum overcurrent trip level to ensure reliable operation while providing enough current ripples for the current mode converter to operate stably. In this case, for 1.2A maximum output current, the maximum inductor ripple current is 400 mA. The inductor size is estimated as following equation:

$$L_{IDEAL} = (V_{IN(MAX)} - V_{OUT}) / I_{RIPPLE} * D_{MIN} * (1 / F_{OSC})$$

Therefore, for $V_{OUT} = 5V$,

The inductor values is calculated to be $L = 7\mu H$.

Chose 6.8 μH or 10 μH

For $V_{OUT} = 3.3V$,

The inductor values is calculated to be $L = 4.9\mu H$.

Chose 4.7 μH

Output Capacitor Selection

For most applications a nominal 22 μF or larger capacitor is suitable. The HM2359 internal compensation is designed for a fixed corner frequency that is equal to

$$FC = \frac{1}{2 * \pi * \sqrt{C_{OUT} * L}} = 20Khz$$

For example, for $V_{OUT} = 5V$, $L = 6.8\mu H$, $C_{OUT} = 22\mu F$.

The output capacitor keeps output ripple small and ensures control-loop stability. The output capacitor must also have low impedance at the switching frequency. Ceramic, polymer, and tantalum capacitors are suitable, with ceramic exhibiting the lowest ESR and high-frequency impedance. Output ripple with a ceramic output capacitor is approximately as follows:

$$V_{RIPPLE} = I_{L(PK)} [1 / (2\pi * f_{OSC} * C_{OUT})]$$

If the capacitor has significant ESR, the output ripple component due to capacitor ESR is as follows:

$$V_{RIPPLE(ESR)} = I_{L(PK)} * ESR$$

Input Capacitor Selection

The input capacitor in a DC-to-DC converter reduces current peaks drawn from the battery or other input power source and reduces switching noise in the controller. The impedance of the input capacitor at the switching frequency should be less than that of the input source so high-frequency switching currents do not pass through the input source. The output capacitor keeps output ripple small and ensures control-loop stability.

Components Selection

V_{OUT} (V)	C_{OUT} (μF)	L (μH)
8	22x2	10 to 15
5	22x2	6.8 to 10
3.3	22x2	4.7 to 10
2.5	22x2	3.3 to 10

PACKAGE OUTLINE

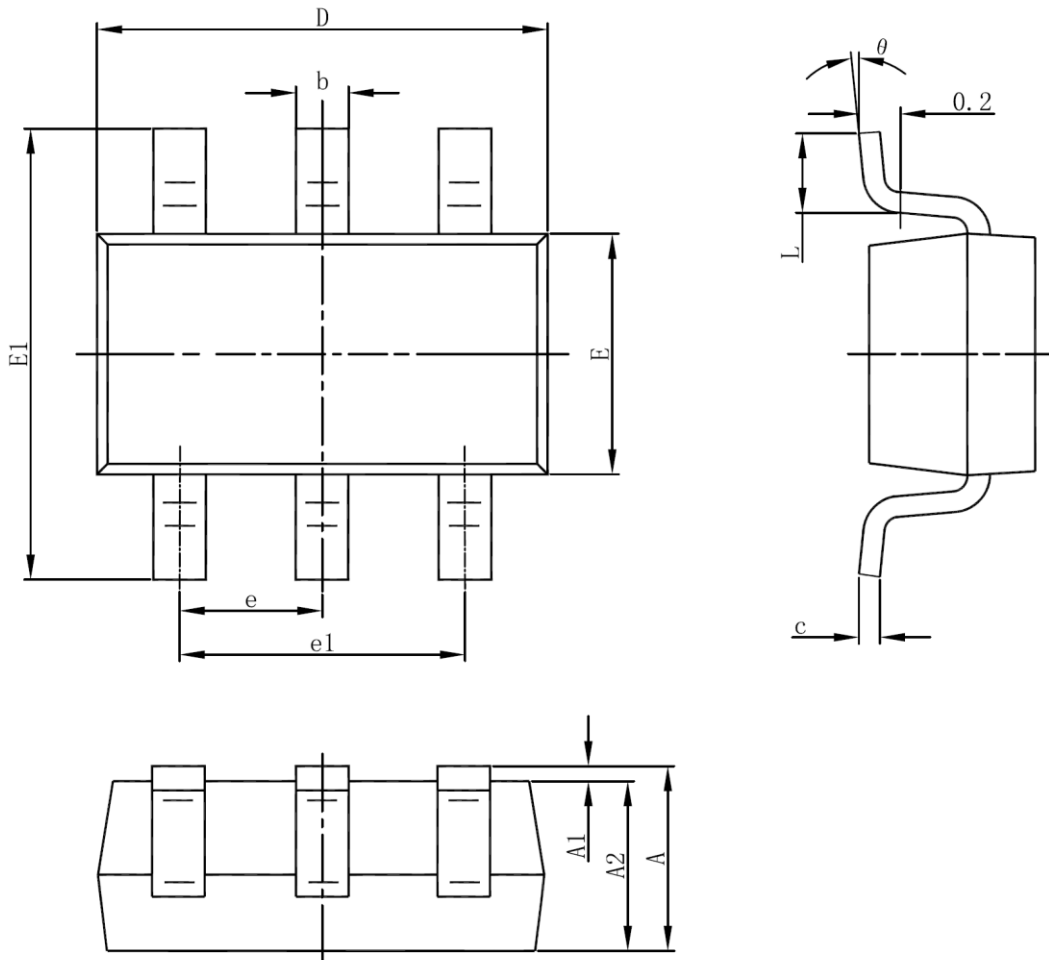

Symbol	Dimensions In Millimeters		Dimensions In Inches	
	Min	Max	Min	Max
A	1.050	1.250	0.041	0.049
A1	0.000	0.100	0.000	0.004
A2	1.050	1.150	0.041	0.045
b	0.300	0.500	0.012	0.020
c	0.100	0.200	0.004	0.008
D	2.820	3.020	0.111	0.119
E	1.500	1.700	0.059	0.067
E1	2.650	2.950	0.104	0.116
e	0.950(BSC)		0.037(BSC)	
e1	1.800	2.000	0.071	0.079
L	0.300	0.600	0.012	0.024
θ	0°	8°	0°	8°