

N-Channel Enhancement Mode Power MOSFET

Description

The HM30N10D uses advanced trench technology and design to provide excellent $R_{DS(ON)}$ with low gate charge. It can be used in a wide variety of applications.

General Features

- $V_{DS} = 100V, I_D = 30A$
 $R_{DS(ON)} < 16m\Omega @ V_{GS}=10V$ (Typ:24m Ω)
- Special process technology for high ESD capability
- High density cell design for ultra low R_{dson}
- Fully characterized avalanche voltage and current
- Good stability and uniformity with high E_{AS}
- Excellent package for good heat dissipation

Application

- Power switching application
- Hard switched and high frequency circuits
- Uninterruptible power supply

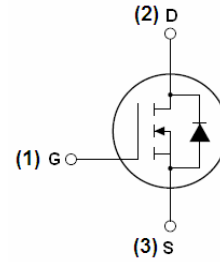

Schematic diagram

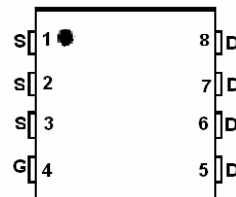

Marking and pin assignment



DFN5X6-8L top view

Package Marking and Ordering Information

Device Marking	Device	Device Package	Reel Size	Tape width	Quantity
HM30N10D	HM30N10D	DFN5X6-8L	-	-	-

Absolute Maximum Ratings ($T_C=25^\circ C$ unless otherwise noted)

Symbol	Parameter	Limit	Unit
V_{DS}	Drain-Source Voltage	100	V
V_{GS}	Gate-Source Voltage	± 20	V
I_D	Drain Current-Continuous	30	A
$I_D(100^\circ C)$	Drain Current-Continuous($T_C=100^\circ C$)	21	A
I_{DM}	Pulsed Drain Current	90	A
P_D	Maximum Power Dissipation	75	W
	Derating factor	0.5	W/ $^\circ C$
T_J, T_{STG}	Operating Junction and Storage Temperature Range	-55 To 175	$^\circ C$

Thermal Characteristic

$R_{\theta JC}$	Thermal Resistance, Junction-to-Case (Note 2)	2.0	$^\circ C/W$
-----------------	---	-----	--------------

Electrical Characteristics (T_c=25°C unless otherwise noted)

Symbol	Parameter	Condition	Min	Typ	Max	Unit
Off Characteristics						
BV _{DSS}	Drain-Source Breakdown Voltage	V _{GS} =0V, I _D =250μA	100	110	-	V
I _{DSS}	Zero Gate Voltage Drain Current	V _{DS} =100V, V _{GS} =0V	-	-	1	μA
I _{GSS}	Gate-Body Leakage Current	V _{GS} =±20V, V _{DS} =0V	-	-	±100	nA
On Characteristics (Note 3)						
V _{GS(th)}	Gate Threshold Voltage	V _{DS} =V _{GS} , I _D =250μA	2	3	4	V
R _{DS(ON)}	Drain-Source On-State Resistance	V _{GS} =10V, I _D =10A	-	12	16	mΩ
g _{FS}	Forward Transconductance	V _{DS} =5V, I _D =10A	-	15	-	S
Dynamic Characteristics (Note 4)						
C _{iss}	Input Capacitance	V _{DS} =25V, V _{GS} =0V, F=1.0MHz	-	2000	-	PF
C _{oss}	Output Capacitance		-	300	-	PF
C _{rss}	Reverse Transfer Capacitance		-	250	-	PF
Switching Characteristics (Note 4)						
t _{d(on)}	Turn-on Delay Time	V _{DD} =50V, R _L =5Ω V _{GS} =10V, R _{GEN} =2.5Ω	-	7	-	nS
t _r	Turn-on Rise Time		-	7	-	nS
t _{d(off)}	Turn-Off Delay Time		-	29	-	nS
t _f	Turn-Off Fall Time		-	7	-	nS
Q _g	Total Gate Charge	V _{DS} =50V, I _D =18A, V _{GS} =10V	-	39	-	nC
Q _{gs}	Gate-Source Charge		-	8	-	nC
Q _{gd}	Gate-Drain Charge		-	12	-	nC
Drain-Source Diode Characteristics						
V _{SD}	Diode Forward Voltage (Note 3)	V _{GS} =0V, I _S =20A	-	-	1.2	V
I _S	Diode Forward Current (Note 2)	-	-	-	30	A
t _{rr}	Reverse Recovery Time	T _J = 25°C, I _F = 18A	-	32	-	nS
Q _{rr}	Reverse Recovery Charge	di/dt = 100A/μs (Note 3)	-	53	-	nC
t _{on}	Forward Turn-On Time	Intrinsic turn-on time is negligible (turn-on is dominated by LS+LD)				

Notes:

1. Repetitive Rating: Pulse width limited by maximum junction temperature.
2. Surface Mounted on FR4 Board, t ≤ 10 sec.
3. Pulse Test: Pulse Width ≤ 300μs, Duty Cycle ≤ 2%.
4. Guaranteed by design, not subject to production

Test Circuit

1) E_{AS} Test Circuit

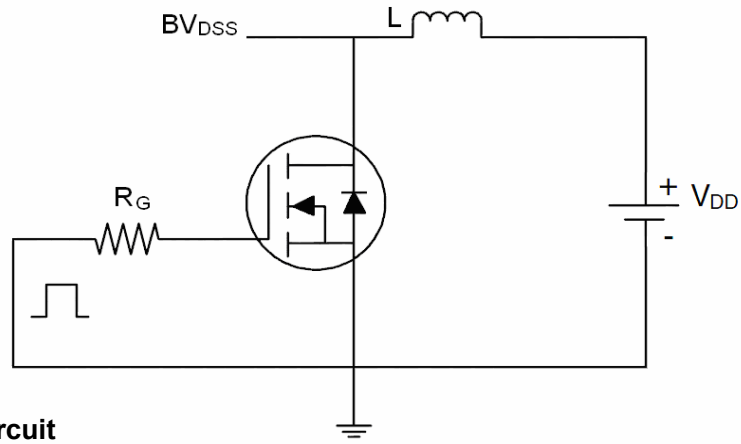

2) Gate Charge Test Circuit

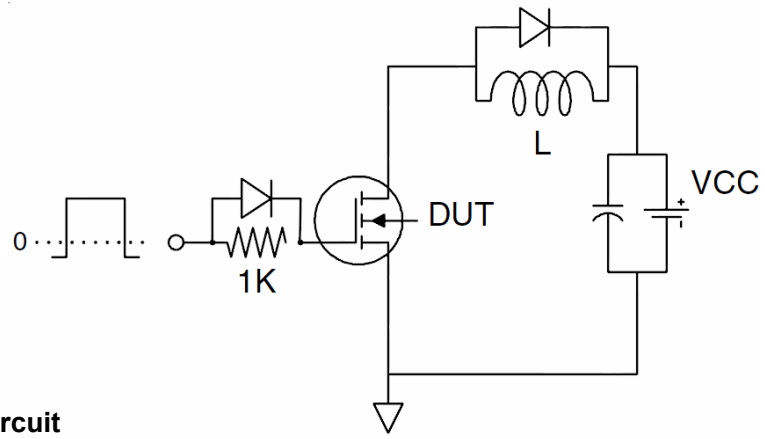

3) Switch Time Test Circuit

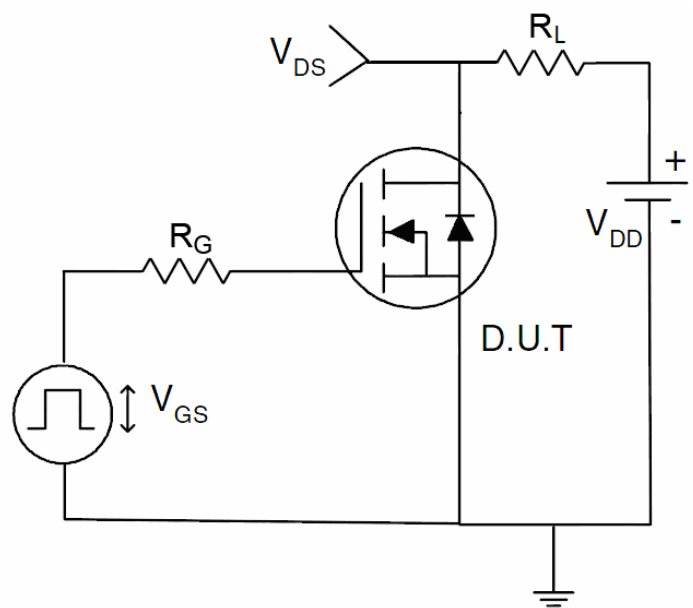

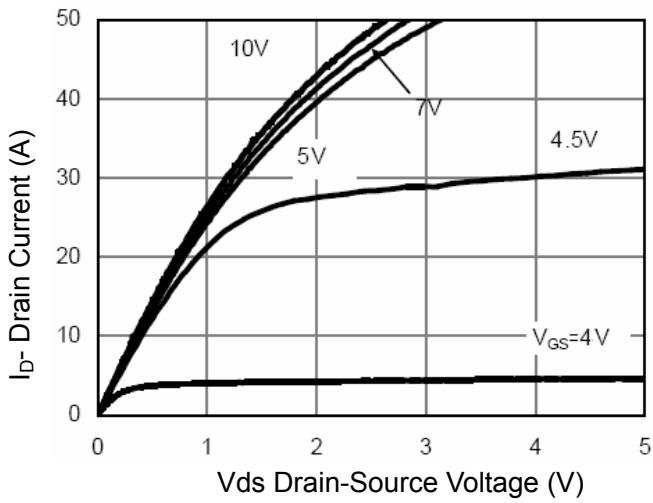

Figure 1 Output Characteristics

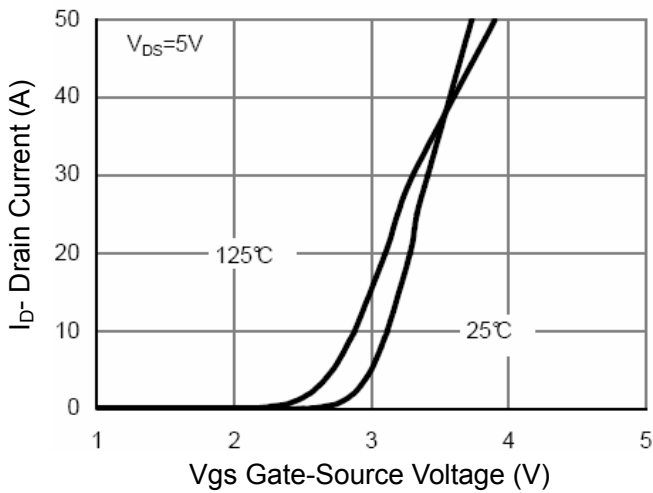

Figure 2 Transfer Characteristics

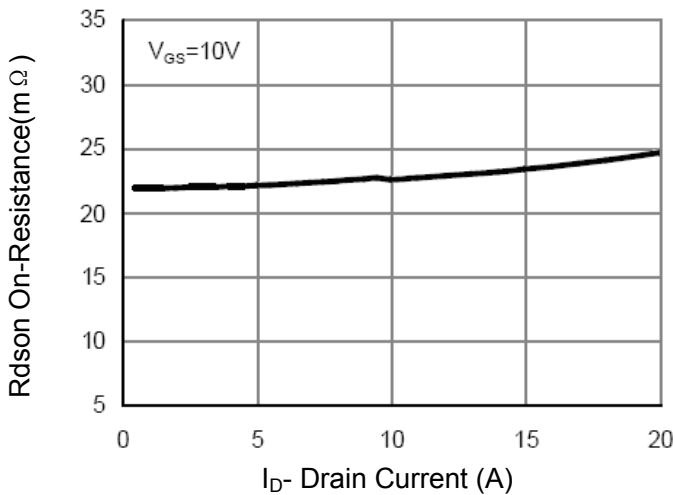

Figure 3 Rdson- Drain Current

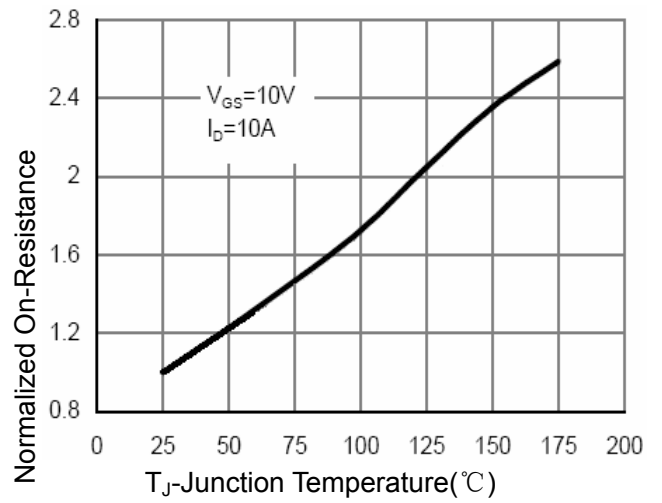

Figure 4 Rdson-Junction Temperature

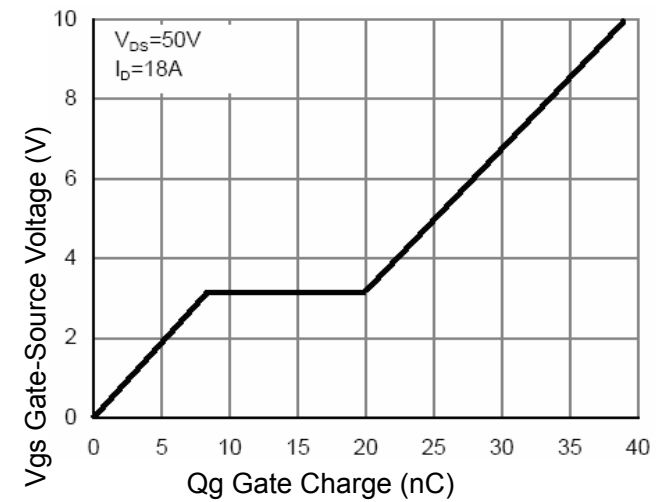

Figure 5 Gate Charge

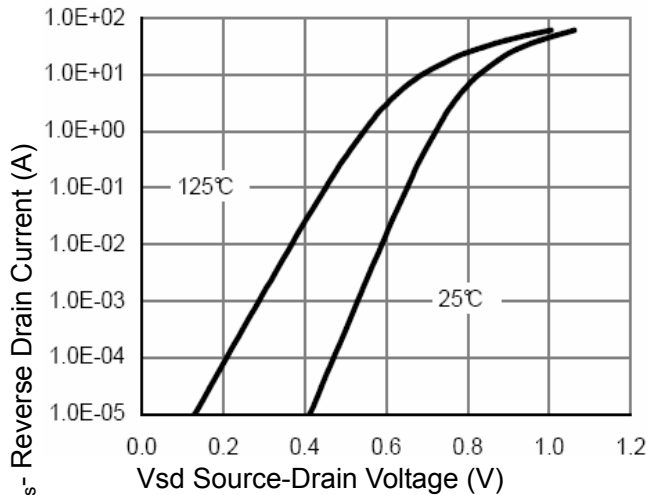

Figure 6 Source- Drain Diode Forward

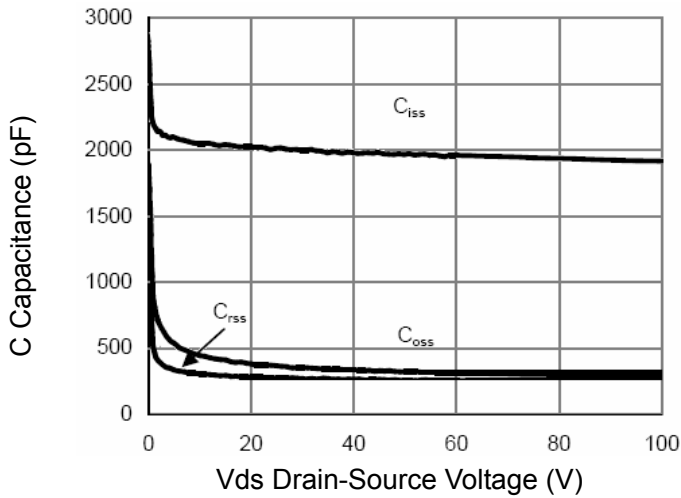

Figure 7 Capacitance vs Vds

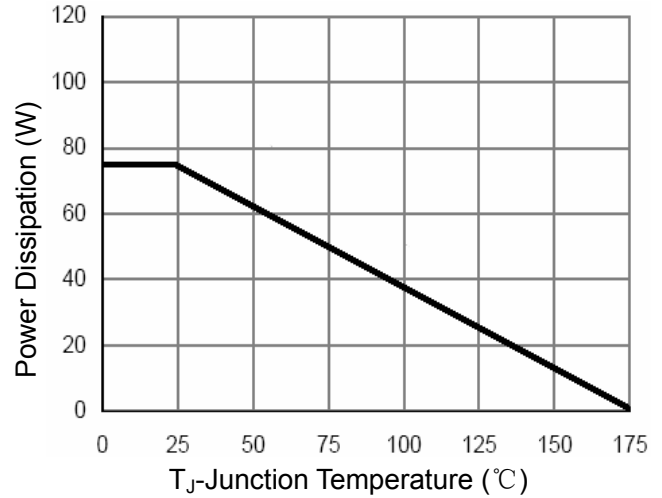

Figure 9 Power De-rating

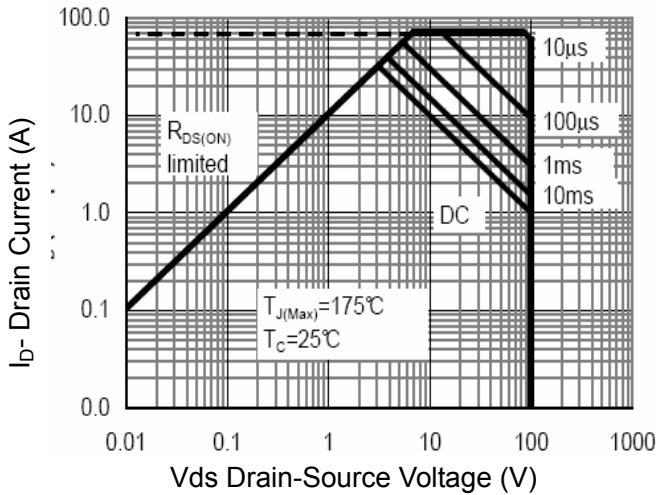

Figure 8 Safe Operation Area

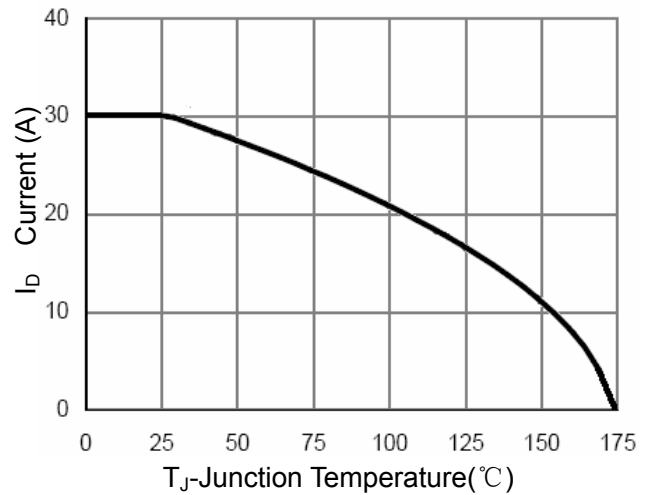

Figure 10 ID Current- Junction Temperature

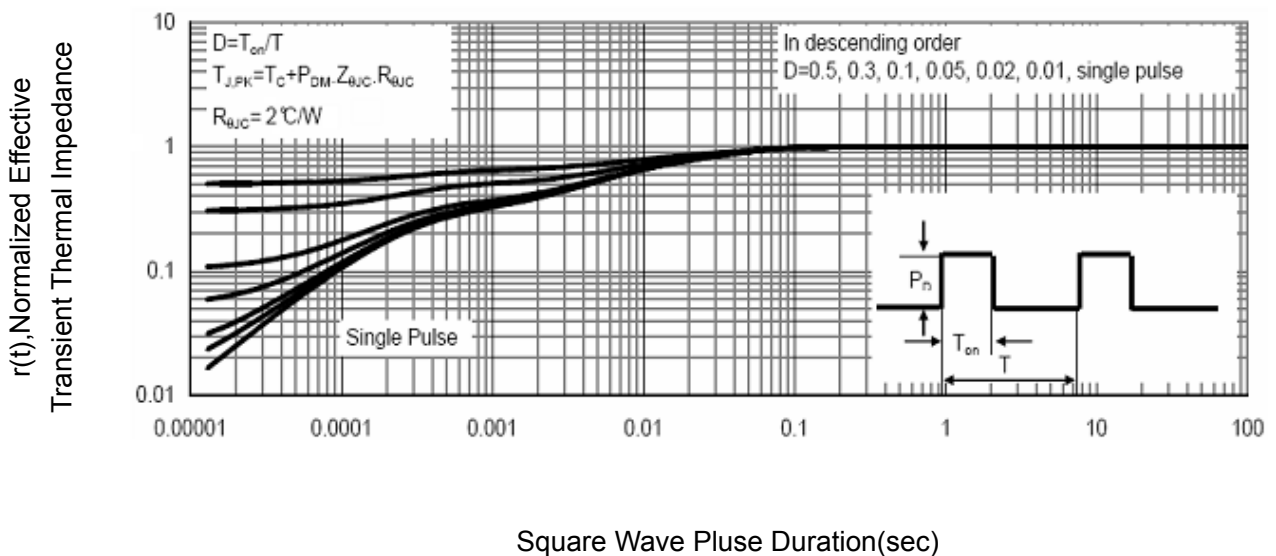
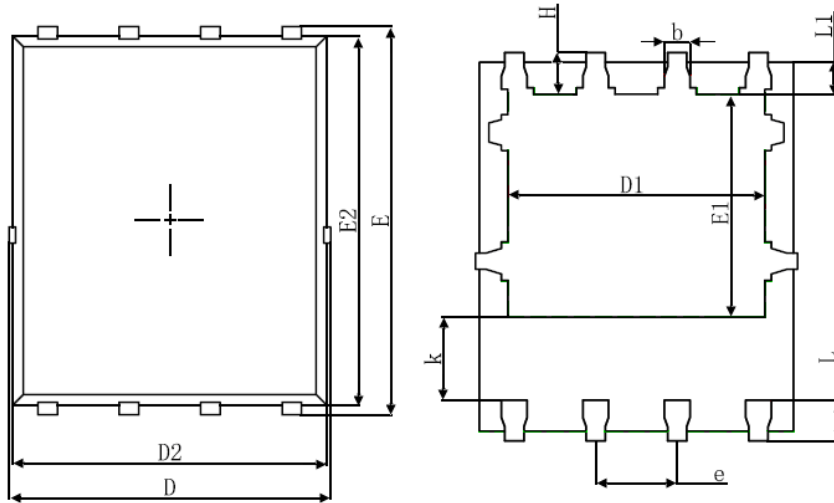

Figure 11 Normalized Maximum Transient Thermal Impedance

DFN5X6-8L Package Information



Top View
 [顶视图]

Bottom View
 [背视图]

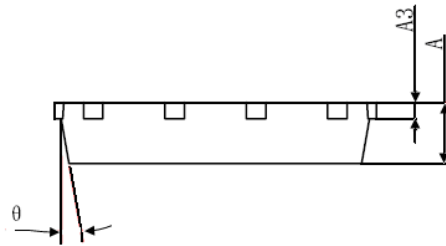

Side View
 [侧视图]

Symbol	Dimensions In Millimeters		Dimensions In Inches	
	Min.	Max.	Min.	Max.
A	0.900	1.000	0.035	0.039
A3	0.254REF.		0.010REF.	
D	4.944	5.096	0.195	0.201
E	5.974	6.126	0.235	0.241
D1	3.910	4.110	0.154	0.162
E1	3.375	3.575	0.133	0.141
D2	4.824	4.976	0.190	0.196
E2	5.674	5.826	0.223	0.229
K	1.190	1.390	0.047	0.055
b	0.035	0.450	0.014	0.018
e	1.270(TYP.)		0.050(TYP.)	
L	0.559	0.711	0.022	0.028
L1	0.424	0.576	0.017	0.023
H	0.574	0.726	0.023	0.029
θ	8°	12°	8°	12°