

## Features

- Wide 8V to 36V Input Voltage Range
- Output Adjustable from 1.25V to 32V
- Maximum Duty Cycle 100%
- Minimum Drop Out 0.3V
- Fixed 180KHz Switching Frequency
- 5A Constant Output Current Capability
- Internal Optimize Power MOSFET
- High efficiency up to 96%
- Excellent line and load regulation
- Built in thermal shutdown function
- Built in current limit function
- Built in output short protection function
- Available in TO263-5L package

## Applications

- LCD Monitor and LCD TV
- Portable instrument power supply
- Telecom / Networking Equipment

## General Description

The HM3105 is a 180 KHz fixed frequency PWM buck (step-down) DC/DC converter, capable of driving a 5A load with high efficiency, low ripple and excellent line and load regulation. Requiring a minimum number of external components, the regulator is simple to use and include internal frequency compensation and a fixed-frequency oscillator.

The PWM control circuit is able to adjust the duty ratio linearly from 0 to 100%. An over current protection function is built inside. When short protection function happens, the operation frequency will be reduced from 180KHz to 48KHz. An internal compensation block is built in to minimize external component count.



**TO263-5L**

Figure1. Package Type of HM3105

## Pin Configurations

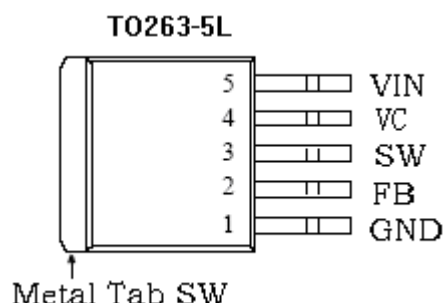

Figure2. Pin Configuration of HM3105 (Top View)

Table 1 Pin Description

Pin Number	Pin Name	Description
1	GND	Ground Pin. Care must be taken in layout. This pin should be placed outside of the Schottky Diode to output capacitor ground path to prevent switching current spikes from inducing voltage noise into HM3105.
2	FB	Feedback Pin (FB). Through an external resistor divider network, FB senses the output voltage and regulates it. The feedback threshold voltage is 1.25V.
3	SW	Power Switch Output Pin (SW). SW is the switch node that supplies power to the output.
4	VC	Internal Voltage Regulator Bypass Capacity. In typical system application, The VC pin connect a 1uf capacity to VIN.
5	VIN	Supply Voltage Input Pin. HM3105 operates from a 8V to 36V DC voltage. Bypass Vin to GND with a suitably large capacitor to eliminate noise on the input.

### Function Block

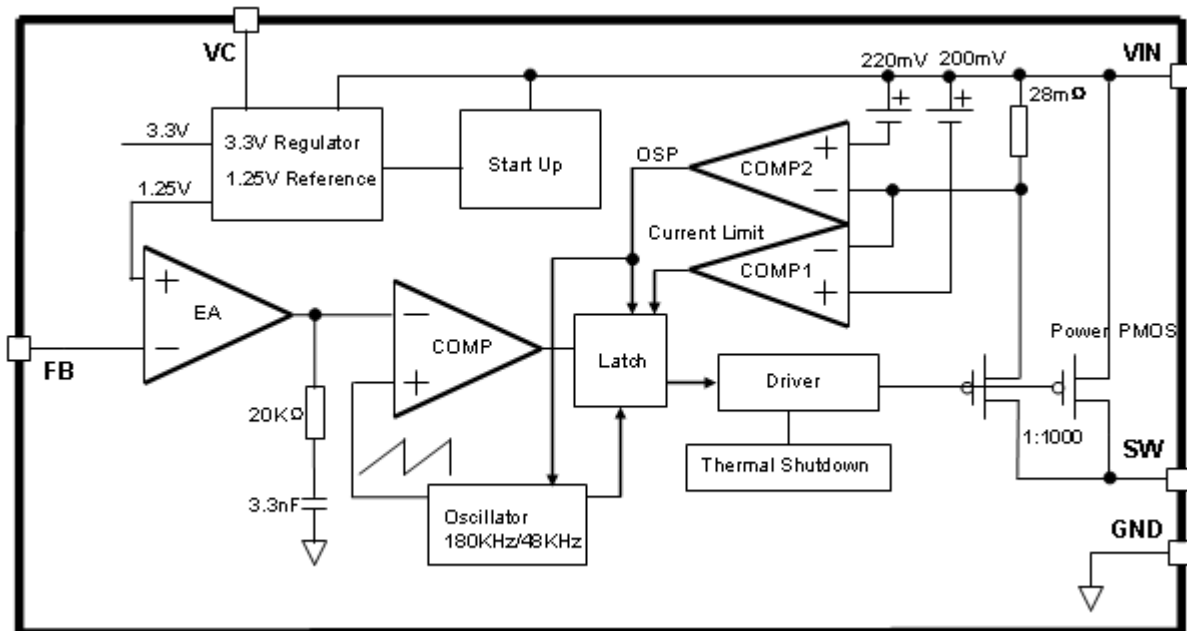

Figure3. Function Block Diagram of HM3105

### Typical Application Circuit

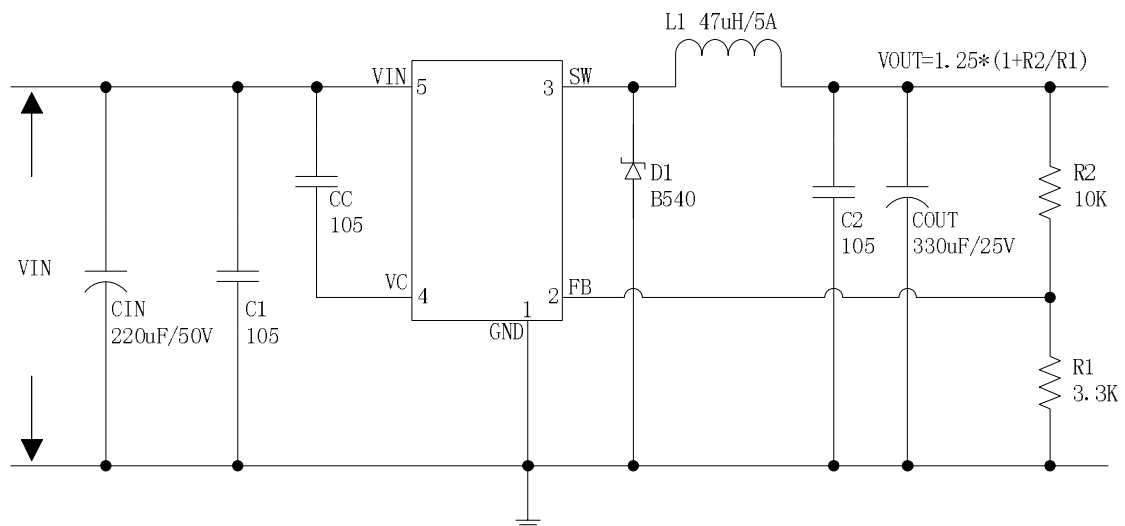

Figure4. HM3105 Typical Application Circuit ( $V_{IN}=8V\sim36V$ ,  $V_{OUT}=5V/5A$ )

### Ordering Information

Package	Temperature Range	Part Number	Marking ID	Packing Type
		Lead Free	Lead Free	
		HM3105	HM3105	

### Absolute Maximum Ratings (Note1)

Parameter	Symbol	Value	Unit
Input Voltage	V <sub>in</sub>	-0.3 to 40	V
Feedback Pin Voltage	V <sub>FB</sub>	-0.3 to V <sub>in</sub>	V
Output Switch Pin Voltage	V <sub>Output</sub>	-0.3 to V <sub>in</sub>	V
Power Dissipation	P <sub>D</sub>	Internally limited	mW
Thermal Resistance (TO263-5L) (Junction to Ambient, No Heatsink, Free Air)	R <sub>JA</sub>	30	°C/W
Operating Junction Temperature	T <sub>J</sub>	-40 to 125	°C
Storage Temperature	T <sub>STG</sub>	-65 to 150	°C
Lead Temperature (Soldering, 10 sec)	T <sub>LEAD</sub>	260	°C
ESD (HBM)		>2000	V

**Note1:** Stresses greater than those listed under Maximum Ratings may cause permanent damage to the device. This is a stress rating only and functional operation of the device at these or any other conditions above those indicated in the operation is not implied. Exposure to absolute maximum rating conditions for extended periods may affect reliability.

### HM3105 Electrical Characteristics

T<sub>a</sub> = 25°C; unless otherwise specified.

Symbol	Parameter	Test Condition	Min.	Typ.	Max.	Unit
<i>System parameters test circuit figure4</i>						
VFB	Feedback Voltage	V <sub>in</sub> = 8V to 40V, V <sub>out</sub> =5V I <sub>load</sub> =0.5A to 5A	1.225	1.25	1.275	V
Efficiency	η	V <sub>in</sub> =12V, V <sub>out</sub> =5V I <sub>out</sub> =5A	-	87	-	%
Efficiency	η	V <sub>in</sub> =24V, V <sub>out</sub> =12V I <sub>out</sub> =4A	-	93	-	%

### Electrical Characteristics (DC Parameters)

V<sub>in</sub> = 12V, GND=0V, V<sub>in</sub> & GND parallel connect a 220uf/50V capacitor; I<sub>out</sub>=500mA, T<sub>a</sub> = 25°C; the others floating unless otherwise specified.

Parameters	Symbol	Test Condition	Min.	Typ.	Max.	Unit
Input operation voltage	V <sub>in</sub>		8		36	V
Quiescent Supply Current	I <sub>q</sub>	V <sub>FB</sub> =V <sub>in</sub>		2.1	5	mA
Oscillator Frequency	F <sub>osc</sub>		144	180	216	KHz
Output Short Frequency	F <sub>osp</sub>			48		KHz
Switch Current Limit	I <sub>L</sub>	V <sub>FB</sub> =0		7		A
Max. Duty Cycle	D <sub>MAX</sub>	V <sub>FB</sub> =0V		100		%
Output Power PMOS	R <sub>dson</sub>	V <sub>FB</sub> =0V, V <sub>in</sub> =12V, I <sub>SW</sub> =5A		60	80	mohm

Typical System Application (VOUT=5V/5A)

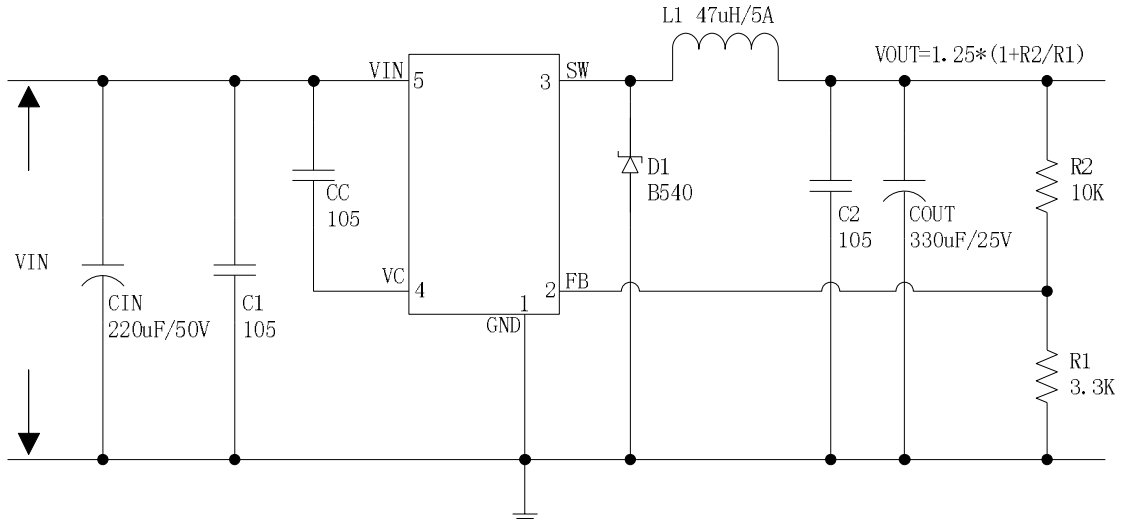

Figure5. HM3105 System Parameters Test Circuit (VIN=8V~36V, VOUT=5V/5A)

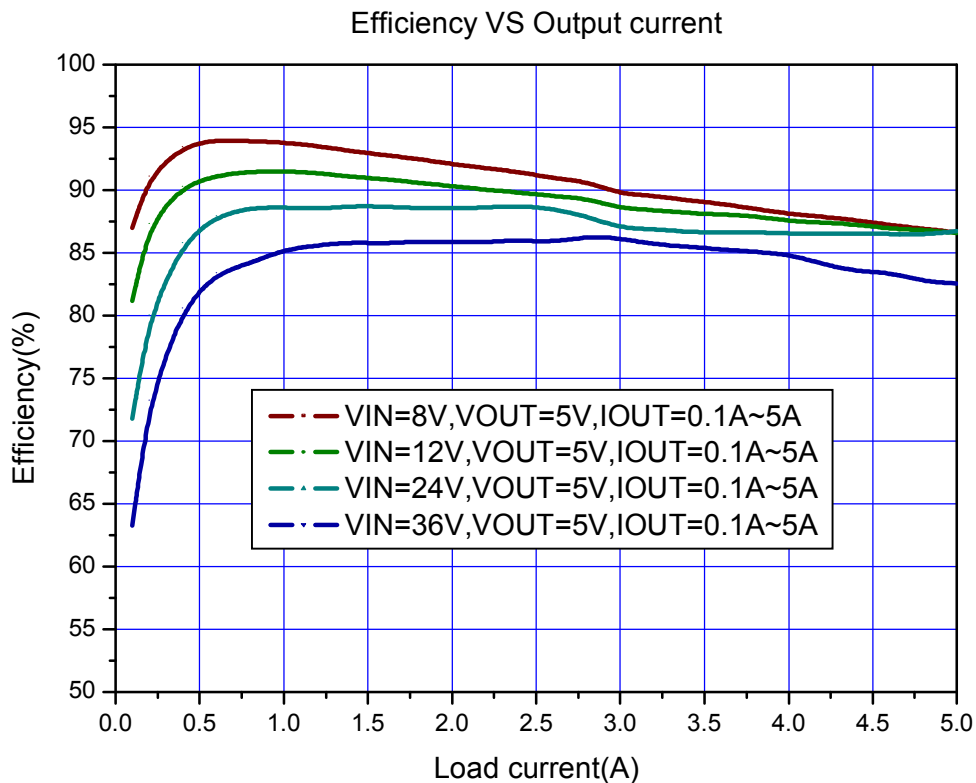

Figure6. HM3105 System Efficiency Curve

Typical System Application (VOUT=12V/4A)

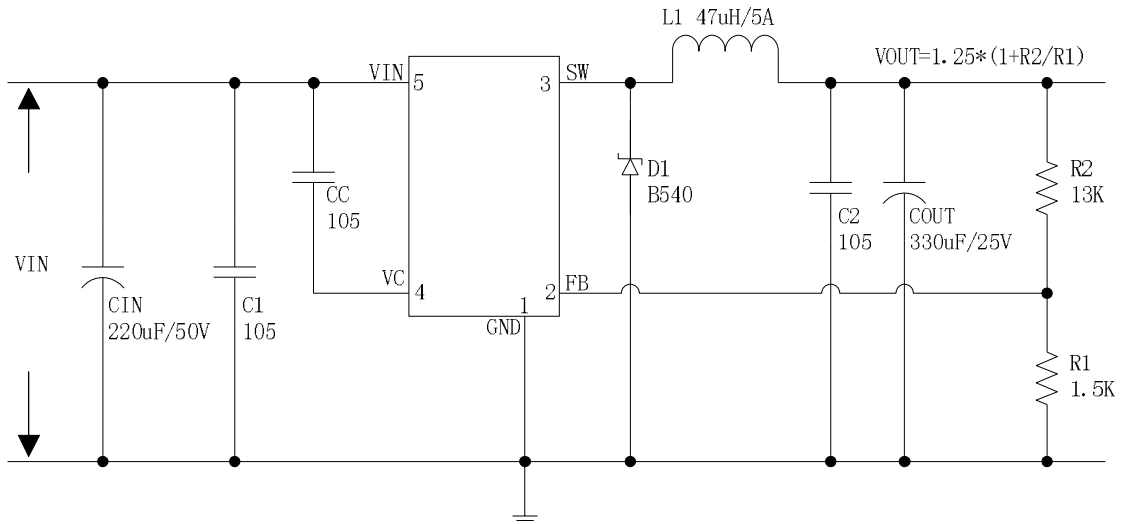

Figure7. HM3105 System Parameters Test Circuit (VIN=15V~36V, VOUT=12V/4A)

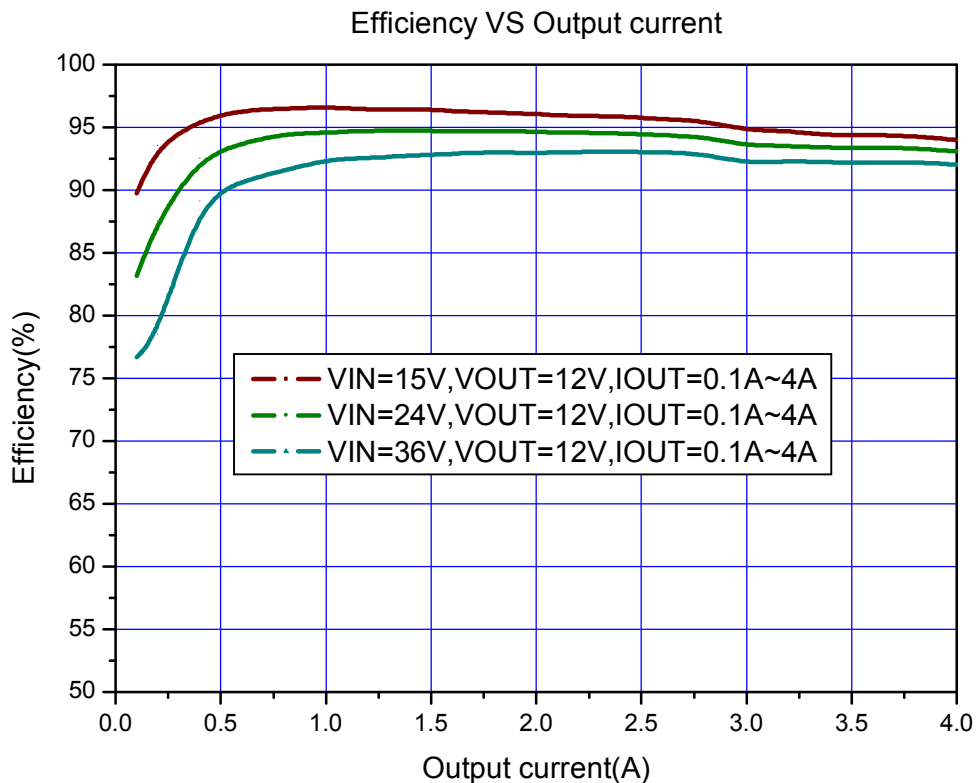

Figure8. HM3105 System Efficiency Curve

### Typical System Application (With Enable function)

Logic level signal shutdown function can be used in typical system application with external components. When the TTL high voltage above 3.3V (referenced to ground, lower than VIN), the converter will shutdown, input current less than 3mA; when the TTL Low voltage below 0.8V (referenced to ground), the converter will turn on.

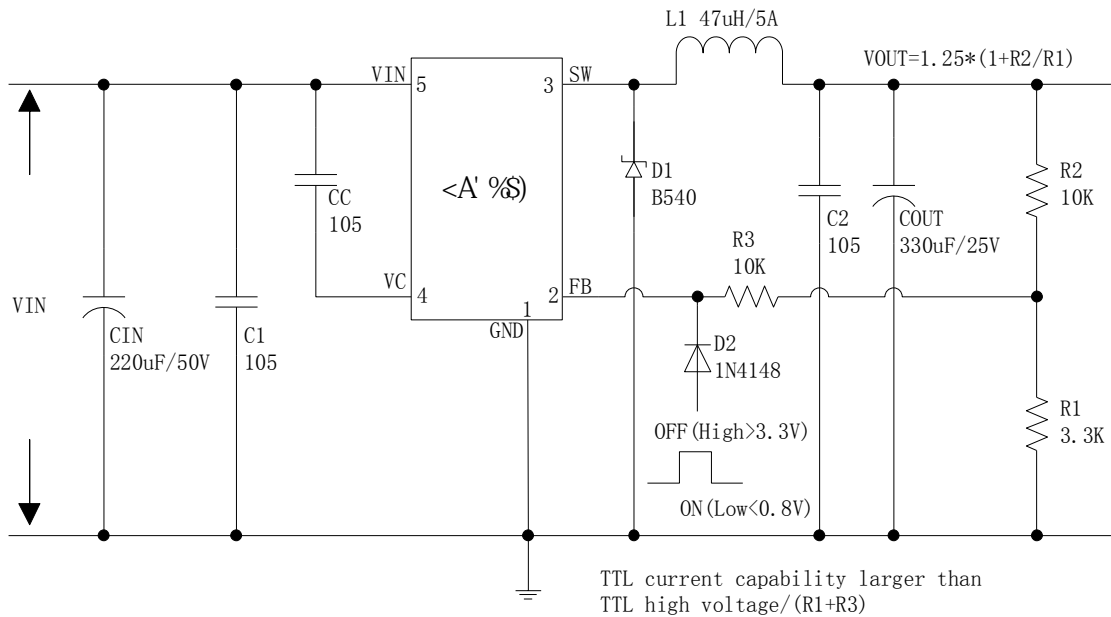
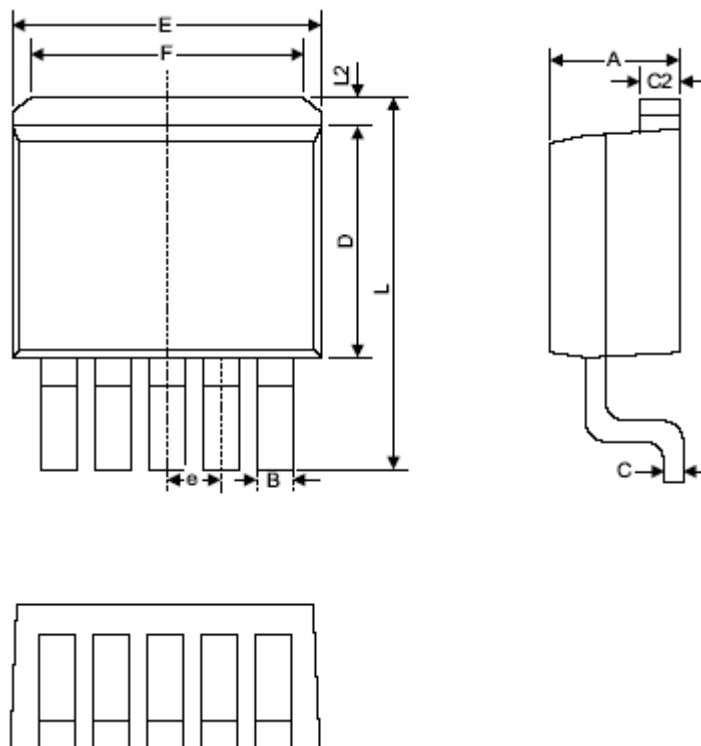

Figure9. HM3105 Typical Application Circuit with Enable Function



## Package Information

### TO263-5L



Symbol	Dimensions In Millimeters		Dimensions In Inches	
	Min.	Max.	Min.	Max.
A	4.06	4.83	0.160	0.190
B	0.76	1.02	0.030	0.040
C	0.36	0.64	0.014	0.025
C2	1.14	1.40	0.045	0.055
D	8.64	9.65	0.340	0.380
E	9.78	10.54	0.385	0.415
e	1.57	1.85	0.062	0.073
F	6.60	7.11	0.260	0.280
L	15.11	15.37	0.595	0.605
L2	-	1.40	-	0.055