

Features

- Wide 8V to 36V Input Voltage Range
- Output Adjustable from 1.25V to 32V
- Maximum Duty Cycle 100%
- Minimum Drop Out 0.3V
- Fixed 180KHz Switching Frequency
- Maximum 3A Switching Current
- Internal Optimize Power MOSFET
- High efficiency
- Excellent line and load regulation
- With output constant current loop
- Built in thermal shutdown function
- Built in current limit function
- Built in output short protection function
- Available in SOP8L package

Applications

- Car Charger
- Battery Charger
- LCD Monitor and LCD TV
- Portable instrument power supply
- Telecom / Networking Equipment

General Description

The HM3109 is a 180 KHz fixed frequency PWM buck (step-down) DC/DC converter, capable of driving a 2.5A load with high efficiency, low ripple and excellent line and load regulation. Requiring a minimum number of external components, the regulator is simple to use and include internal frequency compensation and a fixed-frequency oscillator.

The PWM control circuit is able to adjust the duty ratio linearly from 0 to 100%. An over current protection function is built inside. When short protection function happens, the operation frequency will be reduced from 180KHz to 48KHz. An internal compensation block is built in to minimize external component count.



Figure1. Package Type of HM3109

Pin Configurations

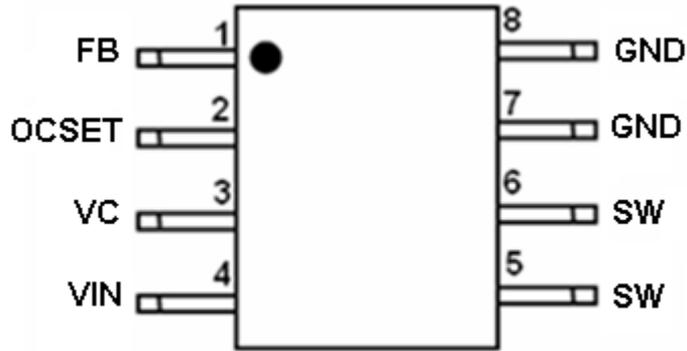

Figure2. Pin Configuration of HM3109 (Top View)

Table 1 Pin Description

Pin Number	Pin Name	Description
1	FB	Feedback Pin (FB). Through an external resistor divider network, FB senses the output voltage and regulates it. The feedback threshold voltage is 1.25V.
2	OCSET	Output Constant Current Set Pin;
3	VC	Internal Voltage Regulator Bypass Capacity. In typical system application, The VC pin connect a 1uf capacity to VIN.
4	VIN	Supply Voltage Input Pin. HM3109 operates from a 8V to 36V DC voltage. Bypass Vin to GND with a suitably large capacitor to eliminate noise on the input.
5,6	SW	Power Switch Output Pin (SW). SW is the switch node that supplies power to the output.
7,8	GND	Ground Pin. Care must be taken in layout. This pin should be placed outside of the Schottky Diode to output capacitor ground path to prevent switching current spikes from inducing voltage noise into HM3109.

Function Block

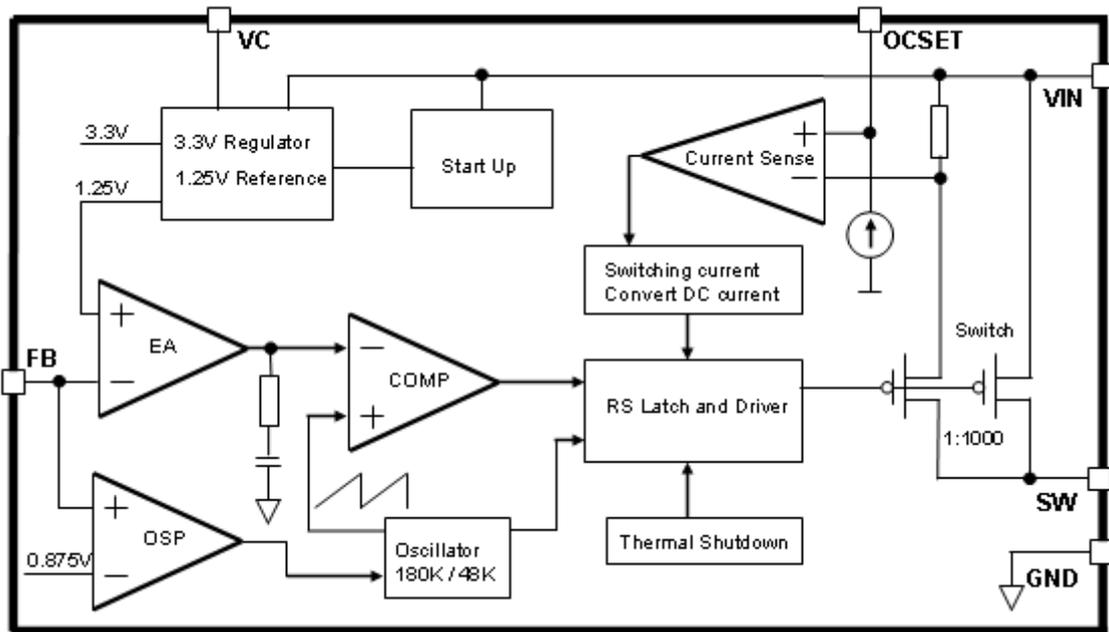

Figure3. Function Block Diagram of HM3109

Typical Application Circuit

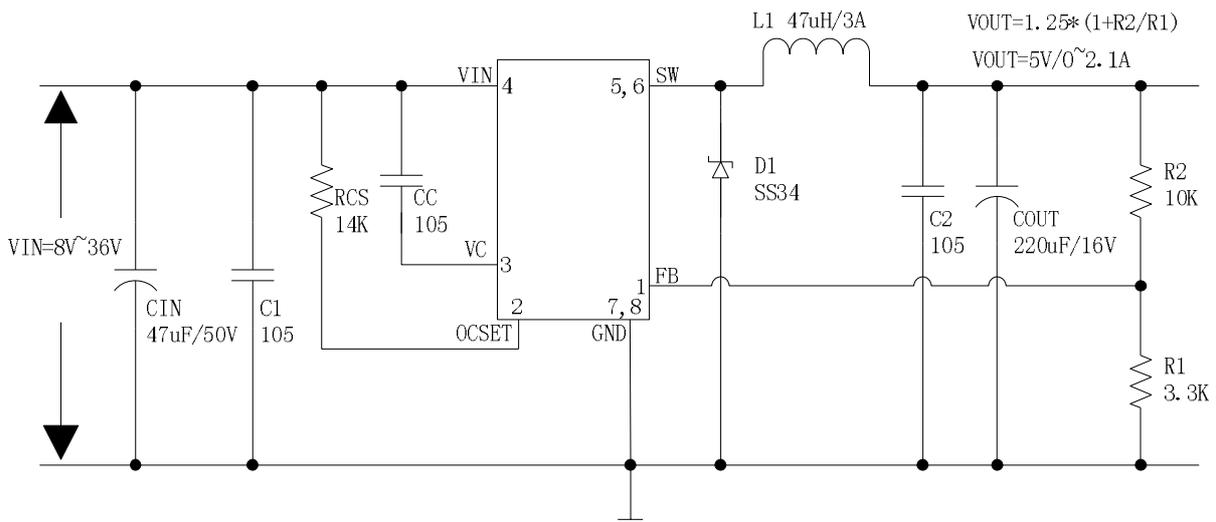

Figure4. HM3109 Typical Application Circuit (VIN=8V~36V, VOUT=5V/2.1A)

Ordering Information

Package	Temperature Range	Part Number	Marking ID	Packing Type
		Lead Free	Lead Free	
		HM3109	HM3109	2500 Units on Tape & Reel

Absolute Maximum Ratings (Note1)

Parameter	Symbol	Value	Unit
Input Voltage	V_{in}	-0.3 to 40	V
Feedback Pin Voltage	V_{FB}	-0.3 to V_{in}	V
Output Switch Pin Voltage	V_{Output}	-0.3 to V_{in}	V
Power Dissipation	P_D	Internally limited	mW
Thermal Resistance (SOP8L) (Junction to Ambient, No Heatsink, Free Air)	R_{JA}	100	°C/W
Operating Junction Temperature	T_J	-40 to 125	°C
Storage Temperature	T_{STG}	-65 to 150	°C
Lead Temperature (Soldering, 10 sec)	T_{LEAD}	260	°C
ESD (HBM)		>2000	V

Note1: Stresses greater than those listed under Maximum Ratings may cause permanent damage to the device. This is a stress rating only and functional operation of the device at these or any other conditions above those indicated in the operation is not implied. Exposure to absolute maximum rating conditions for extended periods may affect reliability.

HM3109 Electrical Characteristics

$T_a = 25^\circ\text{C}$; unless otherwise specified.

Symbol	Parameter	Test Condition	Min.	Typ.	Max.	Unit
<i>System parameters test circuit figure4</i>						
VFB	Feedback Voltage	$V_{in} = 8\text{V to } 36\text{V}, V_{out}=5\text{V}$ $I_{load}=0.5\text{A to } 2.5\text{A}$	1.225	1.25	1.275	V
Efficiency	η	$V_{in}=12\text{V}, V_{out}=5\text{V}$ $I_{out}=2.1\text{A}$	-	89	-	%

Electrical Characteristics (DC Parameters)

$V_{in} = 12\text{V}$, $GND=0\text{V}$, V_{in} & GND parallel connect a $100\mu\text{f}/50\text{V}$ capacitor; $I_{out}=500\text{mA}$, $T_a = 25^\circ\text{C}$; the others floating unless otherwise specified.

Parameters	Symbol	Test Condition	Min.	Typ.	Max.	Unit
Input operation voltage	V_{in}		8		36	V
Quiescent Supply Current	I_q	$V_{FB} = V_{in}$		2.1	5	mA
Oscillator Frequency	F_{osc}		144	180	216	KHz
Output Short Frequency	F_{osp}			48		KHz
Switch Current Limit	I_L	$V_{FB} = 0$		4		A
Max. Duty Cycle	D_{MAX}	$V_{FB}=0\text{V}$		100		%
Output Power PMOS	R_{dson}	$V_{FB}=0\text{V}, V_{in}=12\text{V},$ $I_{SW}=3\text{A}$		60	80	mohm

Typical System Application (VOUT=5V/2.1A)

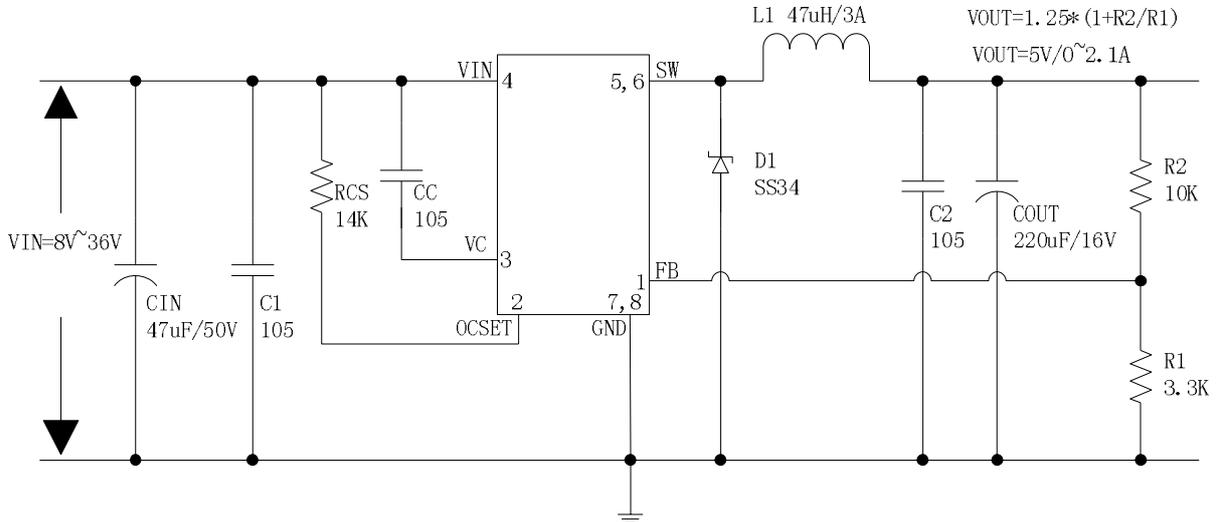

Figure5. HM3109 System Parameters Test Circuit ($V_{IN}=8V\sim 36V$, $V_{OUT}=5V/2.1A$)

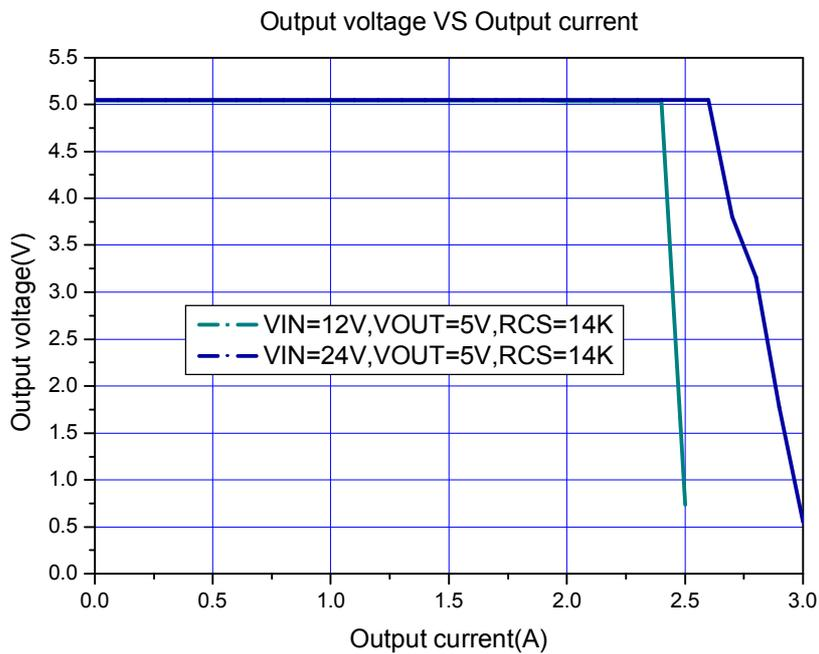

Figure6. HM3109 System Output Constant Current Curve

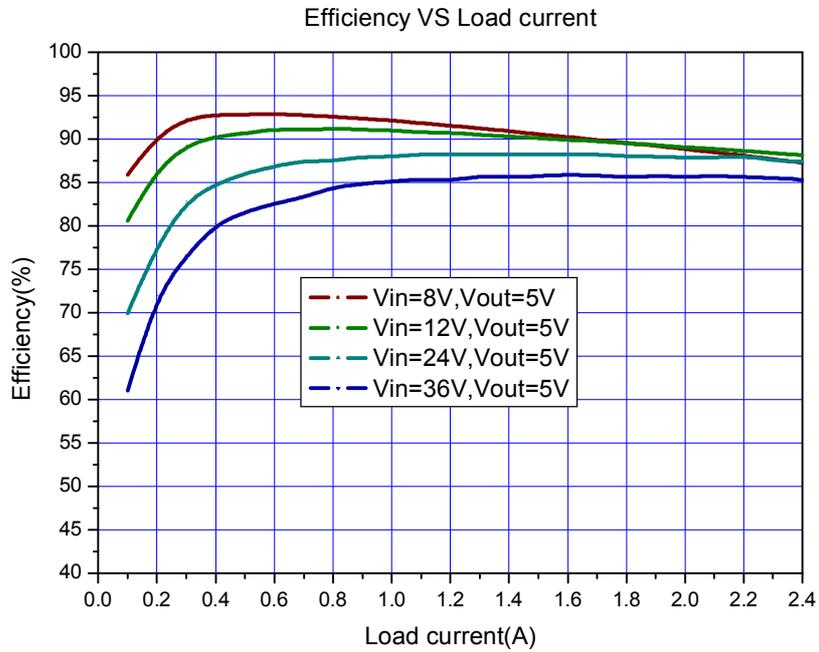

Figure7. HM3109 System Efficiency Curve

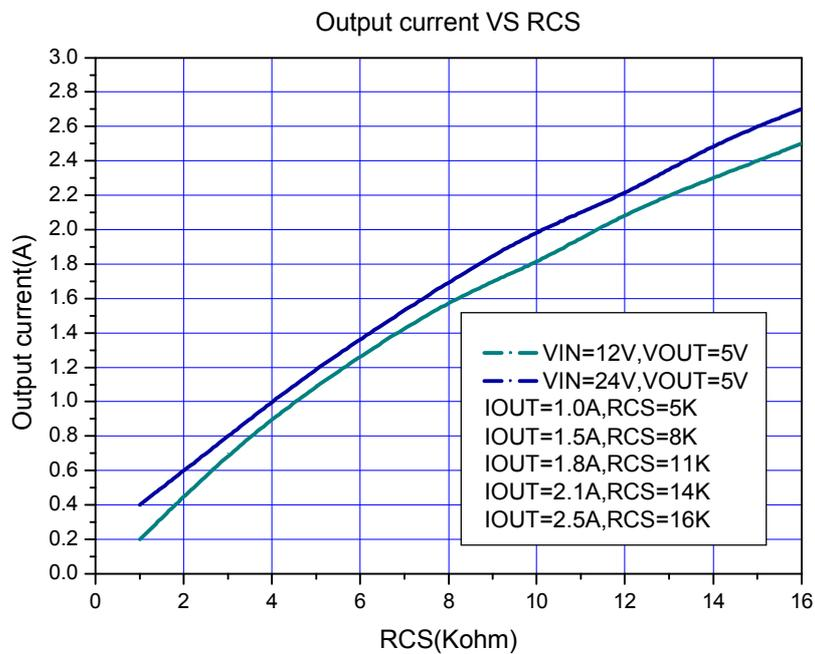

Figure8. RCS VS Output Current Select Curve

Schottky Diode Selection Table

Current	Surface Mount	Through Hole	VR (The same as system maximum input voltage)				
			20V	30V	40V	50V	60V
1A		√	1N5817	1N5818	1N5819		
3A		√	1N5820	1N5821	1N5822		
		√	MBR320	MBR330	MBR340	MBR350	MBR360
	√		SK32	SK33	SK34	SK35	SK36
	√			30WQ03	30WQ04	30WQ05	
		√		31DQ03	31DQ04	31DQ05	
		√	SR302	SR303	SR304	SR305	SR306

