

## 4A 1MHz Synchronous Step-Down DC/DC Converter

### GENERAL DESCRIPTION

The HM3440D synchronous buck converter is a high frequency step-down voltage regulator with current control mode. It can output 4A with excellent line and load regulation. The current is only 100uA at operating and less than 1uA at shutdown. This device is the ideally solution for small space and battery powered consume application, such as cellular phone 、 SSD device and Hand-held device.

The HM3440D integrates PWM controller, power switch and compensation network, required only few components to implement a 4A output switching power supply. It has internal fixed 1MHz frequency and makes application circuit smaller.

The HM3440D is available in an adjustable output voltage version. The adjustable version has wide output range from 0.6V to VIN. The HM3440D series products are available in a DFN3X3-10L package.

### FEATURES

- 2.5V to 5.5V Input Range
- 4A Output Capability
- High Efficiency up to 95%
- Low Quiescent Current 100uA
- Adjustable Output Voltage from 0.6V to VIN
- 1MHz Constant Frequency Operation
- Low Dropout Operation: 100% Duty Cycle
- Under Voltage Lockout, Over Current, Short Current, and Thermal Protection
- Operating Temperature: -40°C to +85°C
- Available in very tiny DFN3X3-10L Package
- RoHS & Green Compliant and 100% Lead (Pb)-Free

### Applications

SSD Device  
 PAD  
 Access Point Router  
 Notebook PC  
 Net PC  
 ServerBoard Mounted Power Supplies

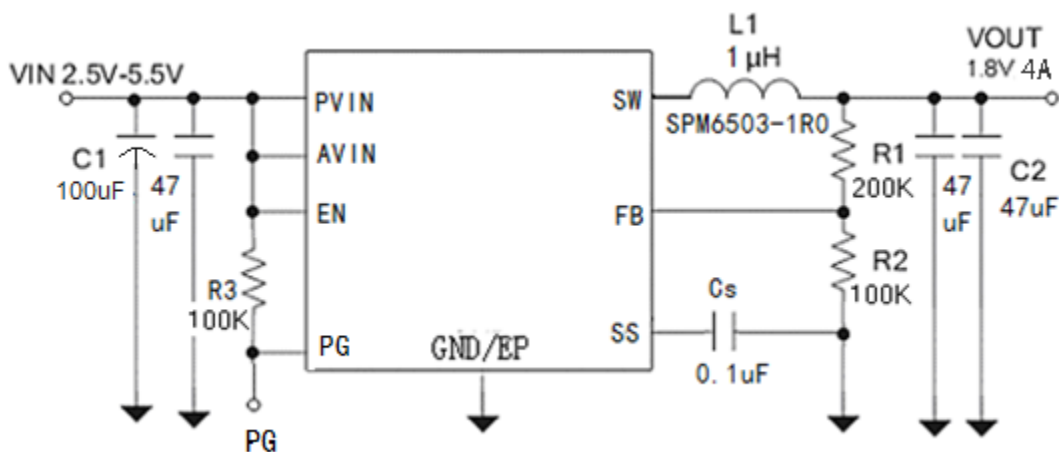

Figure 1. Typical Application Circuit

## ORDERING INFORMATION

PART NUMBER	TEMP RANGE	SWITCHING FREQUENCY	OUTPUT VOLTAGE (V)	OUTPUT CURRENT (A)	PACKAGE	PINS
HM3440D	-40°C to 85°C	1MHz	Adjustable	4	DFN3X3	10

## PIN CONFIGURATION

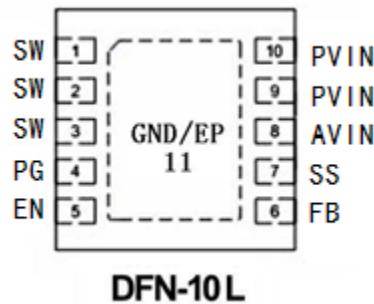

Figure 2. PIN Configuration

## PIN DESCRIPTION

PIN #	NAME	FUNCTION
1; 2; 3	SW	Power Switching Output. SW is the switching node that supplies power to the output. Connect the output LC filter from SW to the output load
4	PG	Power good indicator pin. Open drain output if the output is within +/-10% of regulation; low otherwise
5	EN	Enable Input. EN is a digital input that turns the regulator on or off. Drive EN high to turn on the regulator, driver it low to turn it off.
6	FB	Feedback Input. FB senses the output voltage to regulator that voltage. Drive FB with a resistive voltage divider from the output voltage. The feedback threshold is 0.6V
7	SS	Softstart programming pin. Connect a capacitor from this pin to ground to program the softstart time. 0.1uF set 5ms softstart time, 10nF set 0.5ms softstart time
8	AVIN	Anolog supply input pin. Decouple this pin to GND pin with at least 1uF ceramic cap
9; 10	PVIN	Power Input. VIN supplies the power to the IC, as well as the step-down converter switches. Driver VIN with a 2.5 to 5.5V power source. Bypass VIN to GND with a suitably large capacitor to eliminate noise on the input to the IC.
11	GND/EP	Ground; Exposed pad, Please connect with mass metal for low Rdson & good heat dissipation

## ABSOLUTE MAXIMUM RATINGS

(Note: Do not exceed these limits to prevent damage to the device. Exposure to absolute maximum rating conditions for long periods may affect device reliability.)

PARAMETER	VALUE	UNIT
Supply Voltage VIN	-0.3V to +6V	V
FB, EN Voltage	-0.3V to VIN+0.3V	V
SW Voltage	-0.3V to VIN+0.3V	V
Operating Ambient Temperature	-40 to 85	°C
Maximum Junction Temperature	125	°C
Storage Temperature	-55 to 150	°C
Lead Temperature (Soldering, 10 sec)	300	°C

## ELECTRICAL CHARACTERISTICS

(VIN = 3.6V, TA = 25°C unless otherwise specified)

PARAMETER	SYMBOL	TEST CONDITIONS	MIN	TYP	MAX	UNIT
Input Voltage Range	*VIN		2.5		5.5	V
UVLO Threshold	VUVLO	VHYSTERESIS = 100mV	2.35	2.45	2.5	V
Standby Mode Supply Current		VFB = 0.7V or VOUT = 110%, ILoad = 0		100	150	uA
Shutdown Supply Current		VEN = 0V		0.1	1	
Regulated Feedback Voltage	VFB	Ta = 25°C	0.588	0.6	0.612	V
		0 < Ta < 85°C *	0.5865	0.6	0.6135	
		-40°C < Ta < 85°C *	0.585	0.6	0.615	
Reference Voltage Line Regulation	*	VIN = 2.7V to 5.5V		0.04	0.4	%
Output Voltage Load Regulation	*			1.5		%
PFET Current Limit	Ilim		4.5			A
Oscillator Frequency	FOSC	Iout = 2A		1.0		MHz
Rds(ON) of P-channel FET	*			40		mΩ
Rds(ON) of N-channel FET	*			30		mΩ
Enable Threshold		VIN = 2.5V to 5.5V	0.3	1	1.5	V
Enable Leakage Current			-0.1		0.1	μA
SW Leakage Current		VEN = 0V, Vsw = 0V or 5V, VIN = 5V	-1		1	uA
Thermal Shutdown Temperature	*Tsd			160		°C

Note: \* ---The parameter is guaranteed by design.

## FUNCTIONAL DESCRIPTION

### NORMAL OPERATION

In normal operation the high-side MOSFET turns on each cycle and remains on until the current comparator turns it off. At this point the low-side MOSFET turns on and remains on until either the end of the switching cycle or until the inductor current approaches zero. The error amplifier adjusts the current comparator's threshold as necessary in order to ensure that the output remains in regulation.

### OVER CURRENT OPERATION

The part has internal current limit function, which is detected cycle by cycle. When its maximum inductor current limit is reached the charging cycle is terminated, and the low-side MOSFET is turned on to allow the inductor current to decrease. Under extreme overloads, such as short-circuit conditions, it reduces the oscillator frequency to 220KHz to allow further inductor current reduction and to minimize power dissipation.

## APPLICATION INFORMATION

### INDUCTOR SELECTION

In normal operation, the inductor maintains continuous current to the output. The inductor current has a ripple that is dependent on the inductance value. The high inductance reduces the ripple current. In general, select the inductance by the following equation:

$$L = \frac{V_{OUT} \times (V_{IN} - V_{OUT})}{V_{IN} \cdot f \cdot \Delta I}$$

Where  $V_{OUT}$  is the output voltage,  $V_{IN}$  is the input voltage,  $f$  is the switch frequency, and  $\Delta I$  is the peak-to-peak inductor ripple current. Typically, choose  $\Delta I$  as the 30% of the maximum output current.

Manufacturer	Part Number	Inductance (uH)	DRC max (mΩ)	Dimensions L*W*H (mm3)
TDK	SPM653	1	7.1	7.1*6.5*3
WURTH	744777001	1	8.4	7.3*7.3*4.5

Table 1. Recommend Surface Mount Inductors

### INPUT & OUTPUT CAPACITOR SELECTION

The input & output capacitor reduces input&output voltage ripple to the converter, low ESR ceramic capacitor is highly recommended. For most 3A~4A output load applications, two 47uF MLCC capacitor or One 100uF Tantalum capacitor + One 47uF MLCC Capacitor is used. The input capacitor should be placed as close as possible to VIN and GND. output capacitor should be placed to make the smallest switch circuit. TDK C1206X5R1A476 or Marata GRM31CR60J476ME19L is suitable.

## OUTPUT VOLTAGE PROGRAMMING

In the adjustable version, the output voltage is set by a resistive divider according to the following equation:

$$R_1 = R_2 \times \left( \frac{V_{OUT}}{0.6} - 1 \right)$$

Typically choose R2=100K and determine R1 from the following equation:

## LAYOUT SUGGESTION

The several guidelines should be followed when doing the PCB layout.

- 1, The input and output capacitors should be placed very close to the device, to keep the loop resistance very low and the switching loop very small.
- 2, All ground connection must be tied together. Use a broad ground plane to establish the lowest resistance possible between all connections.
- 3, The FB pin connection should be made as close to the load as possible so that the voltage at the load is the expected regulated value. and place FB network far from Switching node.
- 4, The switch node connection should be low resistance to reduce power losses.
- 5, Please connect EPAD with mass metal for low R<sub>dson</sub> & good heat dissipation

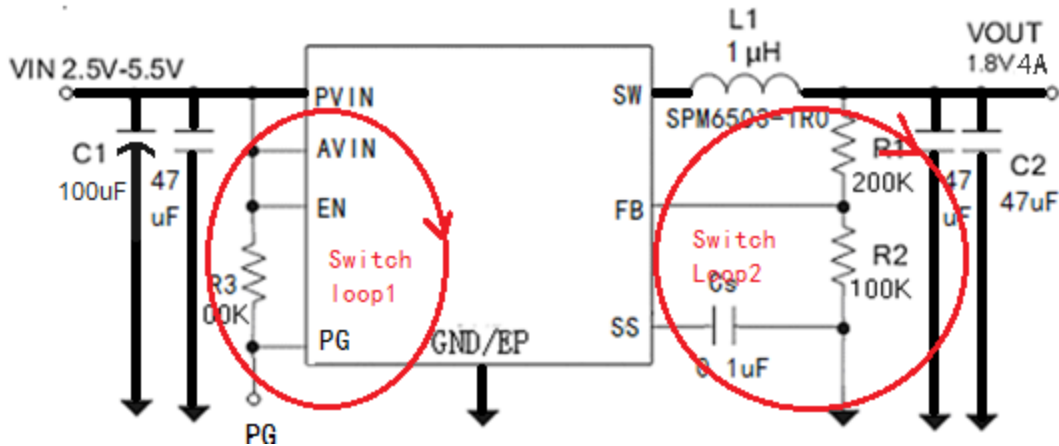

**Big Current Circuit & Switching Loop**

# TYPICAL PERFORMANCE CHARACTERISTICS

(VIN=VEN=5V, L=1.0uH SPM6530T-1R0, CIN=47uF +100uF, COU=47uFx2 , Cs=10nF , if not mentioned)

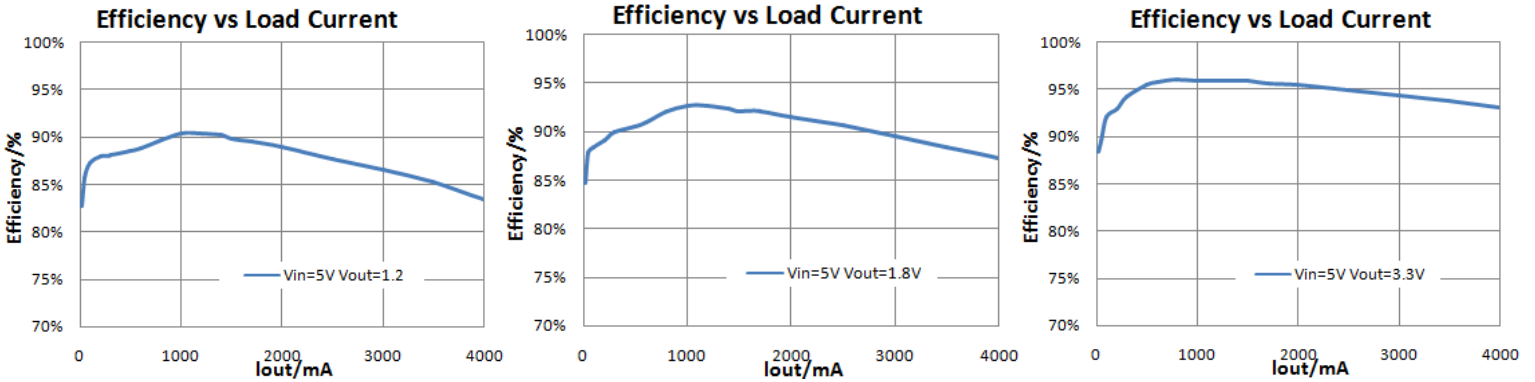

softstart waveform(Cs=10nF I<sub>o</sub>=0A)

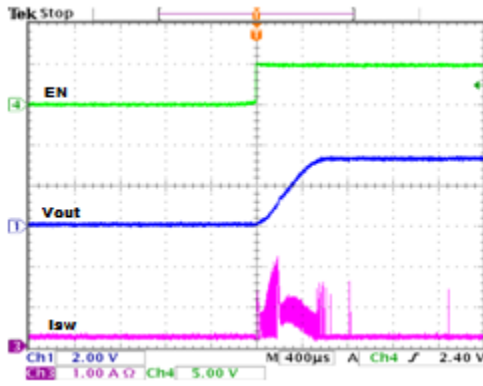

Softstart waveform ( Cs=10nF I<sub>o</sub>=0.5A )

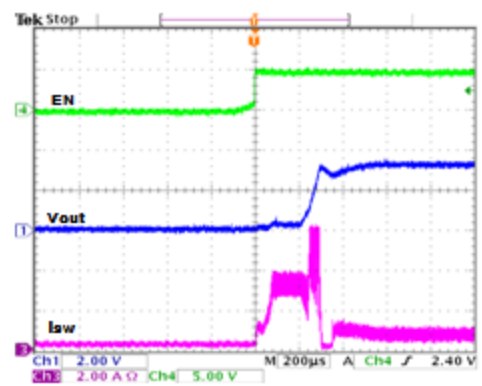

Steady State Waveform(1.8V<sub>out</sub> 0.2A )

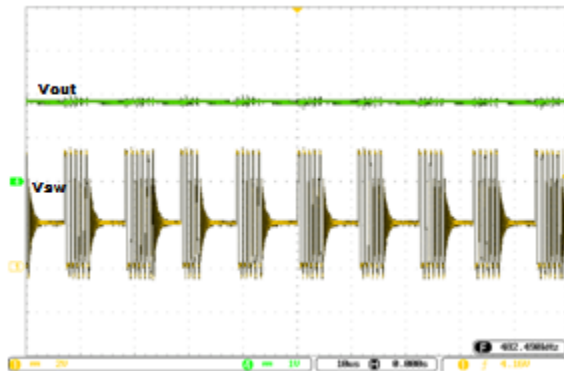

Steady State Waveform(1.8V<sub>out</sub> 4A)

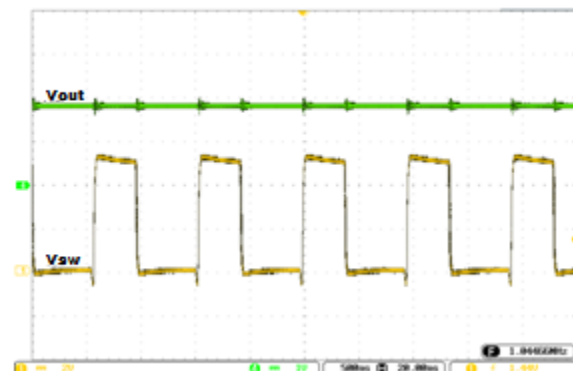

Shut Down Waveform(1.8V<sub>out</sub> 2A )

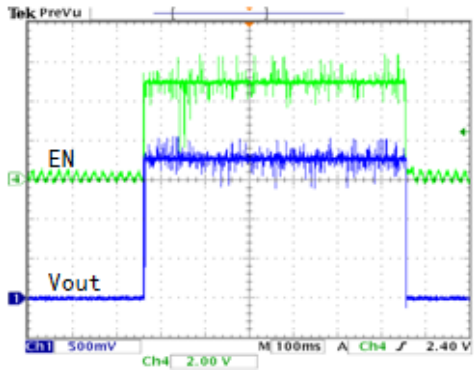

Short Circle Waveform(1.8V<sub>out</sub> 2A)

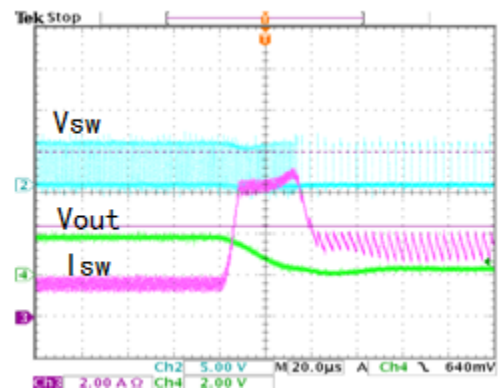

**PACKAGE OUTLINE**

**DFN-10L 3MM X 3MM PACKAGE OUTLINE AND DIMENSIONS**

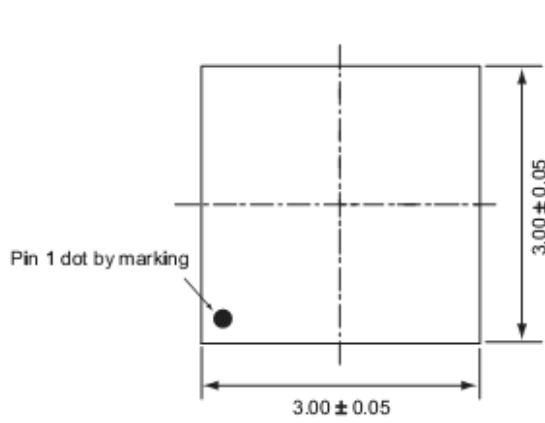

Top View

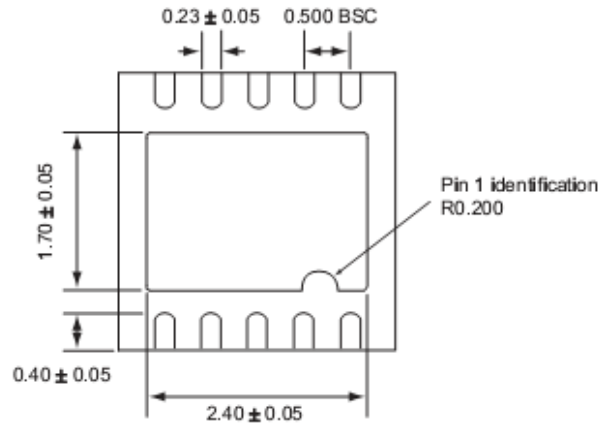

Bottom View

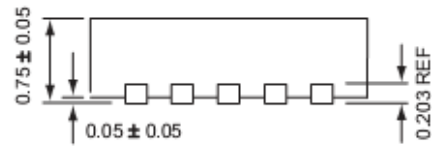

Side View

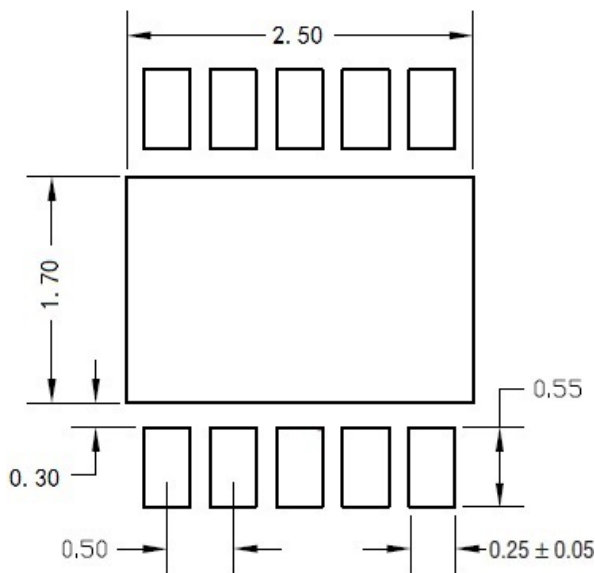

Recommended Solder Pitch and Dimensions