

### General Description:

HM4N90I, the silicon N-channel Enhanced VDMOSFETs, is obtained by the self-aligned planar Technology which reduce the conduction loss, improve switching performance and enhance the avalanche energy. The transistor can be used in various power switching circuit for system miniaturization and higher efficiency. The package form is TO-251, which accords with the RoHS standard.

### Features:

- **Fast Switching**
- **Low ON Resistance**( $R_{dson} \leq 3\Omega$ )
- **Low Gate Charge** (Typical Data:25.2nC)
- **Low Reverse transfer capacitances**(Typical:7.4pF)
- **100% Single Pulse avalanche energy Test**

### Applications:

Power switch circuit of adaptor and charger.

**Absolute** (Tc= 25°C unless otherwise specified):

Symbol	Parameter	Rating	Units
$V_{DSS}$	Drain-to-Source Voltage	900	V
$I_D$	Continuous Drain Current	4	A
	Continuous Drain Current $T_C = 100^\circ\text{C}$	2.5	A
$I_{DM}^{a1}$	Pulsed Drain Current	16	A
$V_{GS}$	Gate-to-Source Voltage	$\pm 30$	V
$E_{AS}^{a2}$	Single Pulse Avalanche Energy	150	mJ
$dv/dt^{a3}$	Peak Diode Recovery dv/dt	5.0	V/ns
$P_D$	Power Dissipation	100	W
	Derating Factor above 25°C	0.8	W/°C
$V_{ESD(G-S)}$	Gate source ESD (HBM-C= 100pF, R=1.5kΩ)	4000	V
$T_J, T_{stg}$	Operating Junction and Storage Temperature Range	150, -55 to 150	°C
$T_L$	Maximum Temperature for Soldering	300	°C

$V_{DSS}$	900	V
$I_D$	4	A
$P_D(T_C=25^\circ\text{C})$	100	W
$R_{DS(ON)Typ}$	2.6	$\Omega$

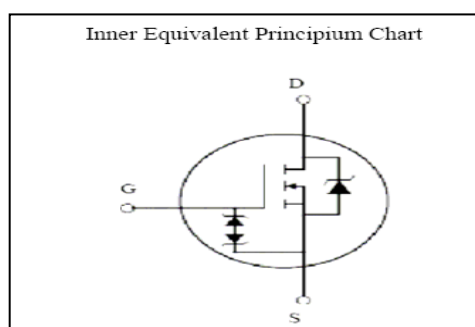
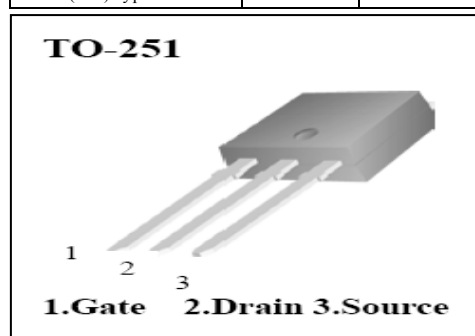

**Electrical Characteristics** (Tc= 25°C unless otherwise specified):

<b>OFF Characteristics</b>						
Symbol	Parameter	Test Conditions	Rating			Unit s
			Min.	Typ.	Max.	
V <sub>DSS</sub>	Drain to Source Breakdown Voltage	V <sub>GS</sub> =0V, I <sub>D</sub> =250μA	900	--	--	V
Δ BV <sub>DSS</sub> / Δ T <sub>J</sub>	Bvdss Temperature Coefficient	ID=250uA, Reference 25°C	--	0.92	--	V/°C
I <sub>DSS</sub>	Drain to Source Leakage Current	V <sub>DS</sub> = 900V, V <sub>GS</sub> = 0V, T <sub>a</sub> = 25°C	--	--	25	μA
		V <sub>DS</sub> = 720V, V <sub>GS</sub> = 0V, T <sub>a</sub> = 125°C	--	--	250	μA
I <sub>GSS(F)</sub>	Gate to Source Forward Leakage	V <sub>GS</sub> = +20V	--	--	10	μA
I <sub>GSS(R)</sub>	Gate to Source Reverse Leakage	V <sub>GS</sub> = -20V	--	--	-10	μA

<b>ON Characteristics</b>						
Symbol	Parameter	Test Conditions	Rating			Units
			Min.	Typ.	Max.	
R <sub>DS(ON)</sub>	Drain-to-Source On-Resistance	V <sub>GS</sub> =10V, I <sub>D</sub> =2A	--	2.6	3.0	Ω
V <sub>GS(TH)</sub>	Gate Threshold Voltage	V <sub>DS</sub> = V <sub>GS</sub> , I <sub>D</sub> = 250μA	2.0	--	4.0	V
Pulse width tp ≤ 300μs, δ ≤ 2%						

<b>Dynamic Characteristics</b>						
Symbol	Parameter	Test Conditions	Rating			Units
			Min.	Typ.	Max.	
g <sub>fs</sub>	Forward Transconductance	V <sub>DS</sub> =15V, I <sub>D</sub> =2A	--	5	--	S
R <sub>g</sub>	Gate resistance	f = 1.0MHz		1.9		Ω
C <sub>iss</sub>	Input Capacitance	V <sub>GS</sub> = 0V V <sub>DS</sub> = 25V f = 1.0MHz	--	835	--	pF
C <sub>oss</sub>	Output Capacitance		--	76	--	
C <sub>rss</sub>	Reverse Transfer Capacitance		--	7.4	--	

<b>Resistive Switching Characteristics</b>						
Symbol	Parameter	Test Conditions	Rating			Units
			Min.	Typ.	Max.	
t <sub>d(ON)</sub>	Turn-on Delay Time	I <sub>D</sub> =4A V <sub>DD</sub> =450V R <sub>G</sub> =10Ω	--	16	--	ns
t <sub>r</sub>	Rise Time		--	17	--	
t <sub>d(OFF)</sub>	Turn-Off Delay Time		--	43	--	
t <sub>f</sub>	Fall Time		--	14	--	
Q <sub>g</sub>	Total Gate Charge	I <sub>D</sub> =4A V <sub>DD</sub> =720V V <sub>GS</sub> = 10V	--	25.2	--	nC
Q <sub>gs</sub>	Gate to Source Charge		--	4	--	
Q <sub>gd</sub>	Gate to Drain ("Miller") Charge		--	12.2	--	

Source-Drain Diode Characteristics						
Symbol	Parameter	Test Conditions	Rating			Units
			Min.	Typ.	Max.	
$I_S$	Continuous Source Current (Body Diode)		--	--	4	A
$I_{SM}$	Maximum Pulsed Current (Body Diode)		--	--	16	A
$V_{SD}$	Diode Forward Voltage	$I_S=4A, V_{GS}=0V$	--	--	1.5	V
$t_{rr}$	Reverse Recovery Time	$I_S=4A, T_j = 25^\circ C$ $di_F/dt=100A/us,$ $V_{GS}=0V$	--	382	--	ns
$Q_{rr}$	Reverse Recovery Charge		--	1792	--	nC
$I_{RRM}$	Reverse Recovery Current		--	9.4	--	A
Pulse width $t_p \leq 300\mu s, \delta \leq 2\%$						

Symbol	Parameter	Max.	Units
$R_{\theta JC}$	Junction-to-Case	1.25	$^\circ C/W$
$R_{\theta JA}$	Junction-to-Ambient	100	$^\circ C/W$

<sup>a1</sup>: Repetitive rating; pulse width limited by maximum junction temperature

<sup>a2</sup>:  $L=10mH, I_D=5.5A, Start T_j=25^\circ C$

<sup>a3</sup>:  $I_{SD}=4A, di/dt \leq 100A/us, V_{DD} \leq BV_{DS}, Start T_j=25^\circ C$

**Characteristics Curve:**

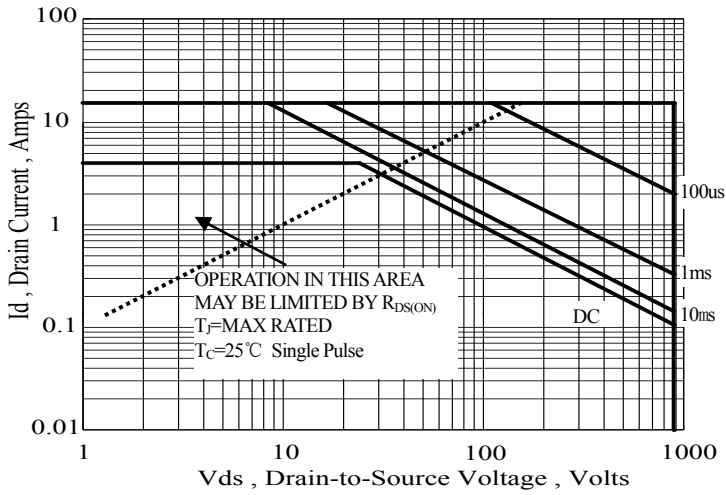

Figure 1 Maximum Forward Bias Safe Operating Area

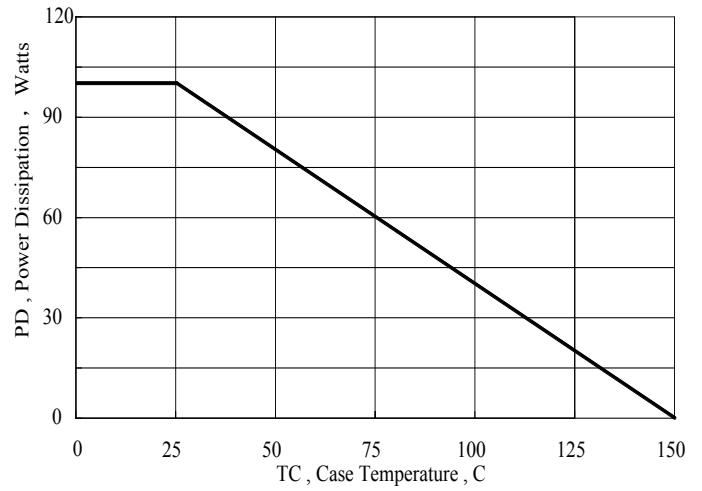

Figure 2 Maximum Power Dissipation vs Case Temperature

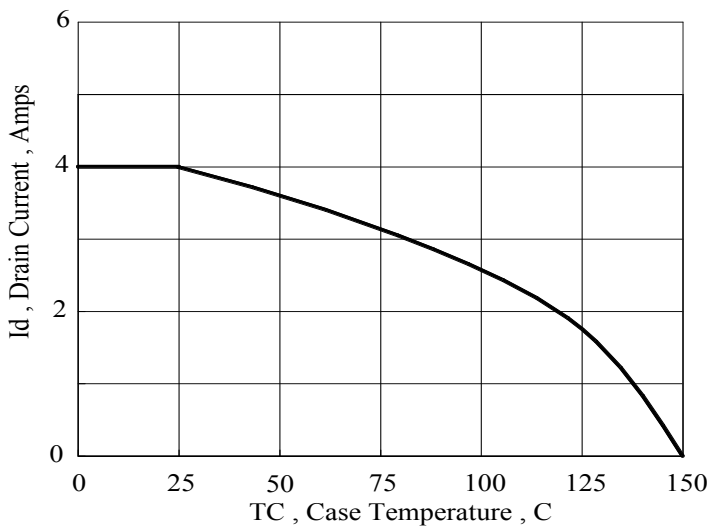

Figure 3 Maximum Continuous Drain Current vs Case Temperature

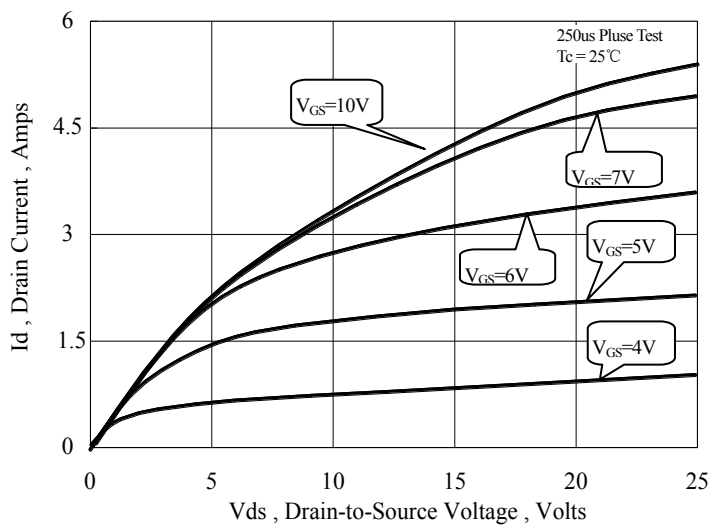
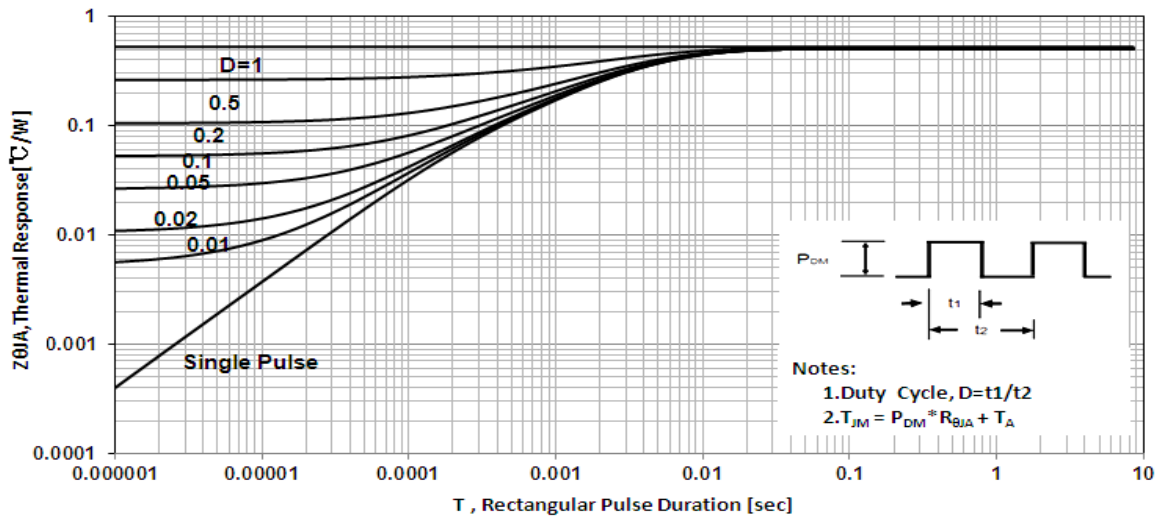

Figure 4 Typical Output Characteristics



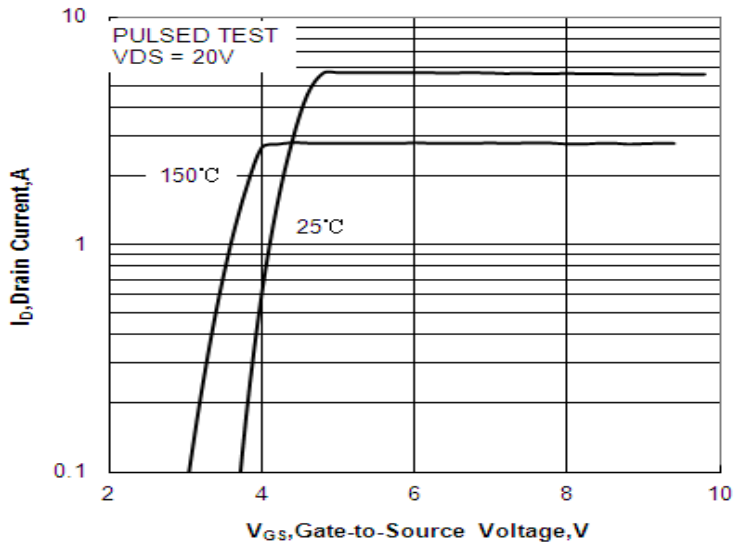

Figure 6 Typical Transfer Characteristics

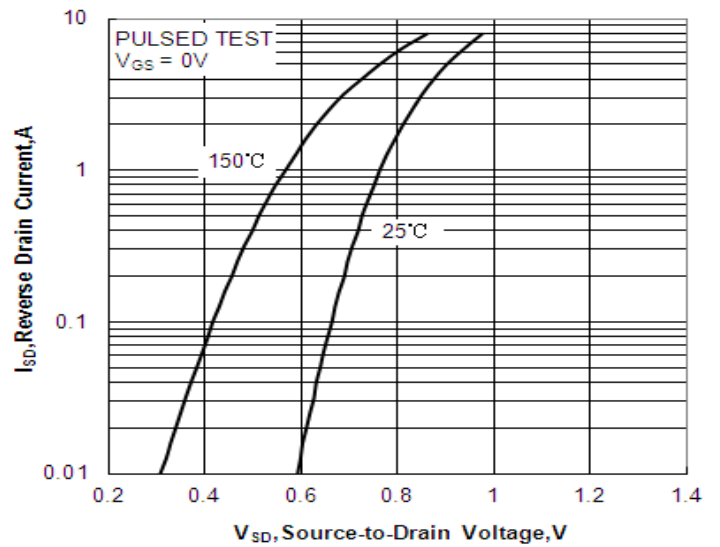

Figure 7 Typical Body Diode Transfer Characteristics

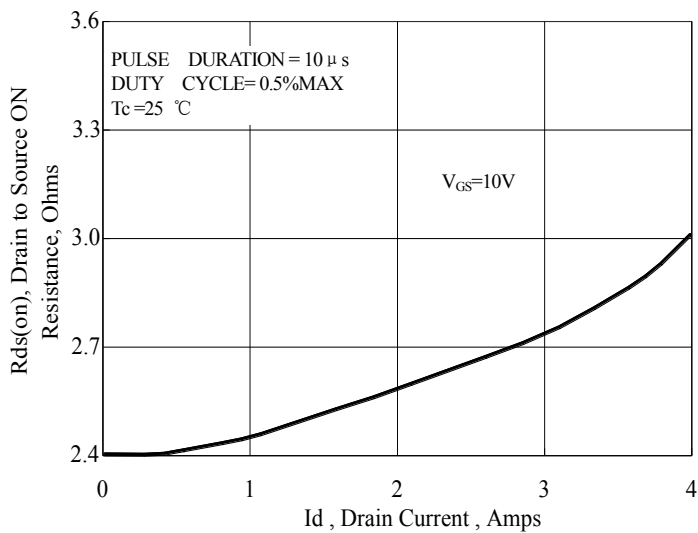

Figure 8 Typical Drain to Source ON Resistance vs Drain Current

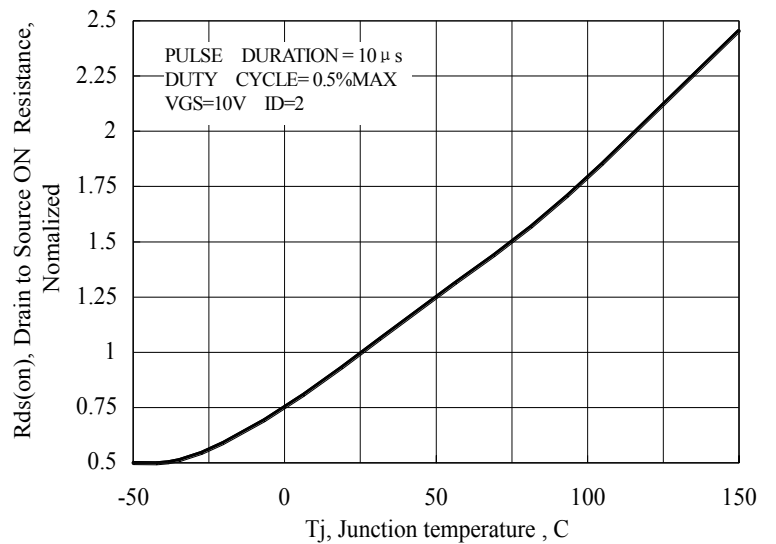

Figure 9 Typical Drain to Source on Resistance vs Junction Temperature

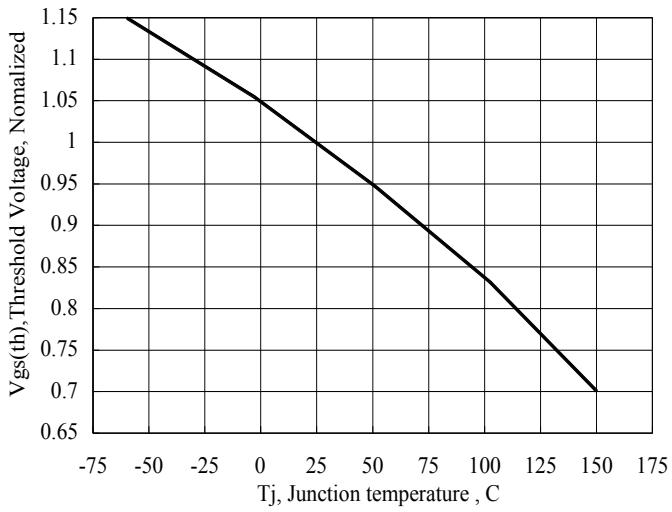

Figure 10 Typical Theshold Voltage vs Junction Temperature

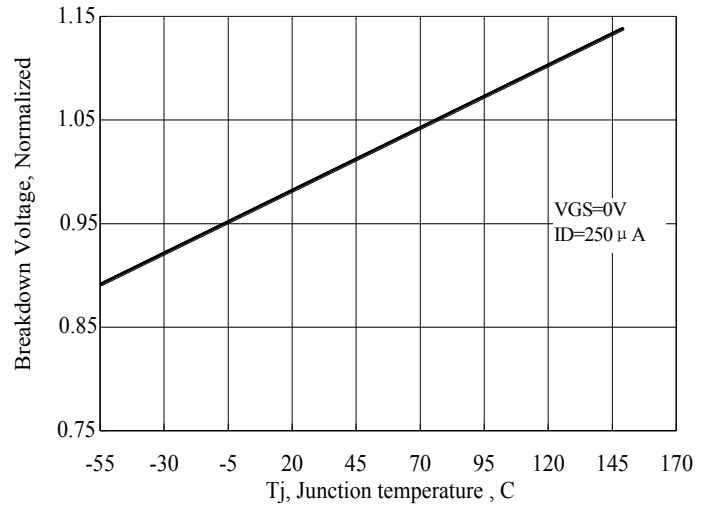

Figure 11 Typical Breakdown Voltage vs Junction Temperature

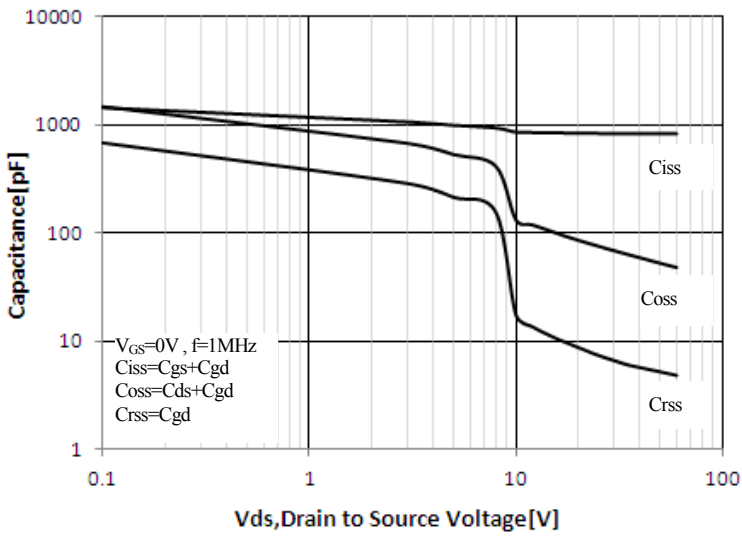

Figure 12 Typical Capacitance vs Drain to Source Voltage

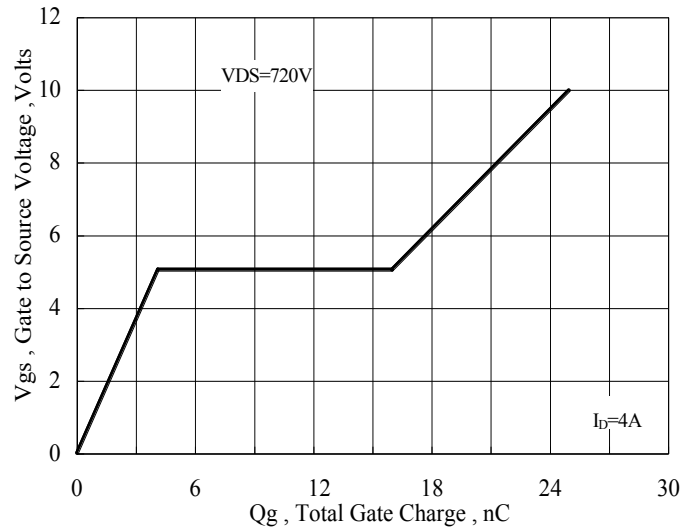

Figure 13 Typical Gate Charge vs Gate to Source Voltage

**Test Circuit and Waveform**

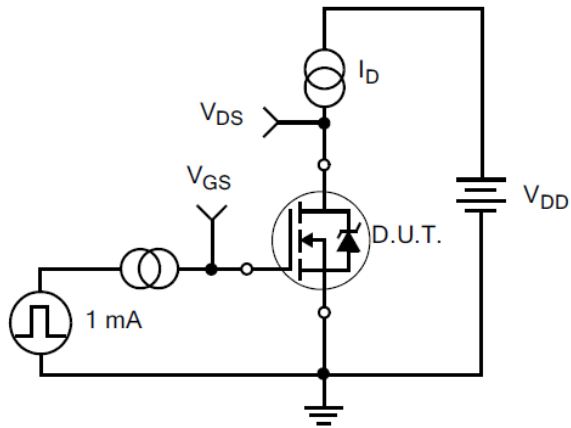

Figure 14. Gate Charge Test Circuit

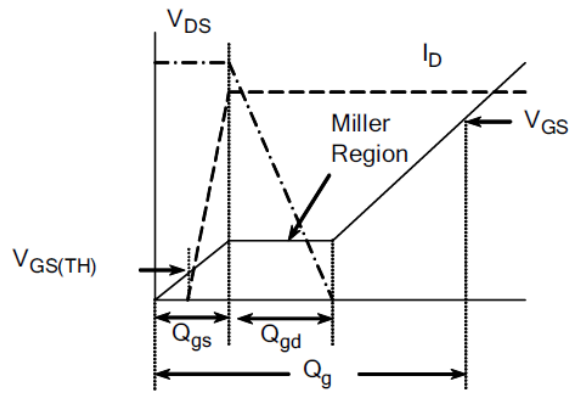

Figure 15. Gate Charge Waveforms

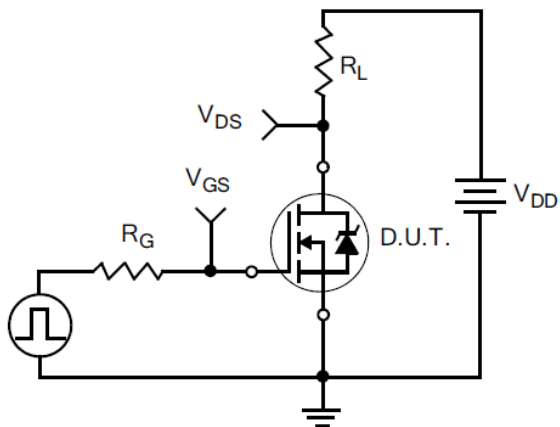

Figure 16. Resistive Switching Test Circuit

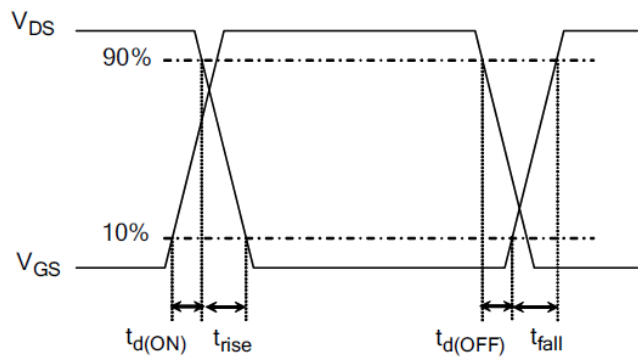

Figure 17. Resistive Switching Waveforms

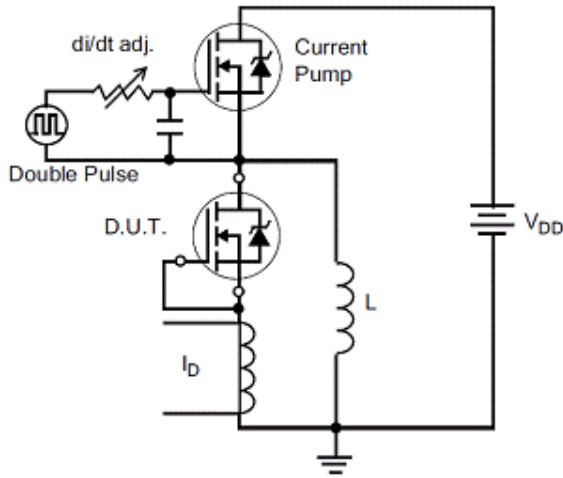

Figure 18. Diode Reverse Recovery Test Circuit

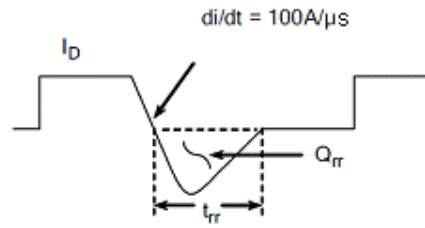

Figure 19. Diode Reverse Recovery Waveform

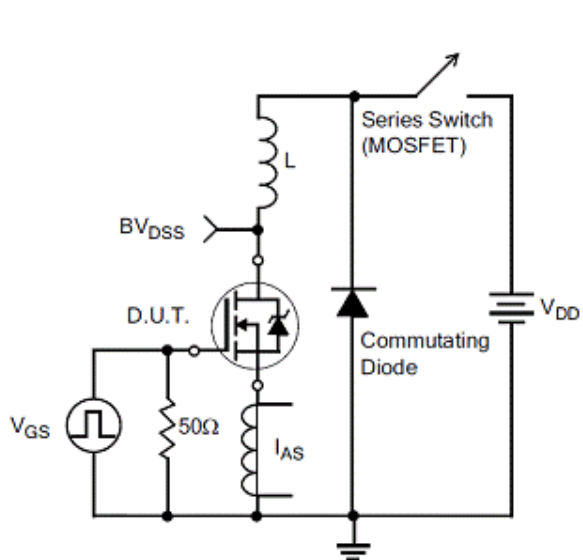

Figure20.Unclamped Inductive Switching Test Circuit

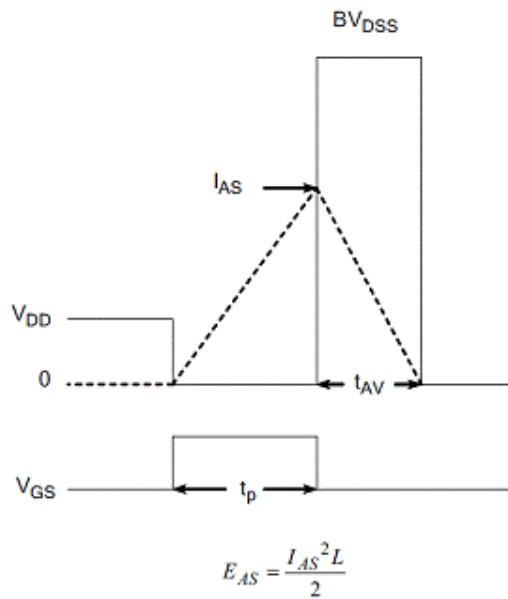
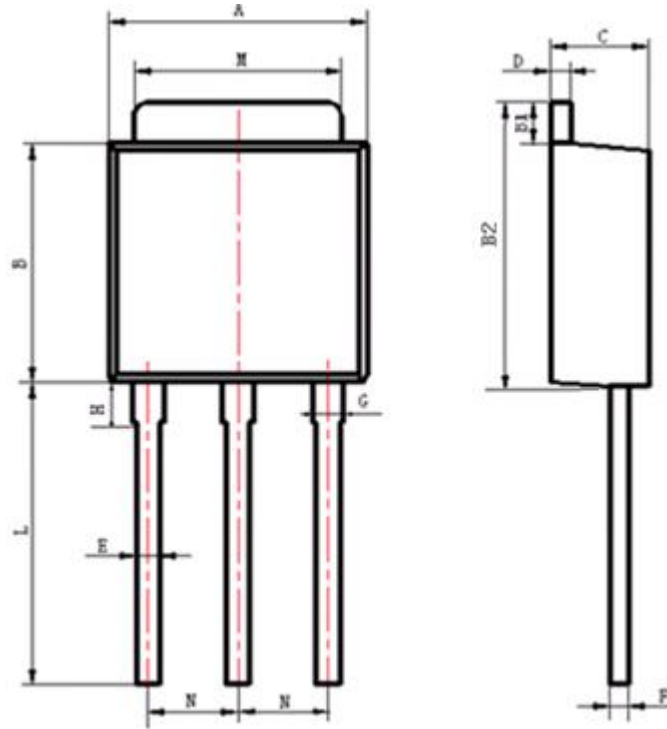

Figure21.Unclamped Inductive Switching Waveform



**Package Information:**



Items	Values(mm)	
	MIN	MAX
A	6.30	6.90
B	5.20	6.30
B1	0.70	1.30
B2	6.80	7.40
C	2.10	2.50
D	0.30	0.60
E	0.50	0.86
F	0.30	0.60
G	0.70	1.00
H	1.40	2.40
L*	7.50	9.80
M	5.10	5.50
N	2.09	2.49

\*: adjustable

TO-251 Package