

HM5705-SOC of Li-Battery Transfer to Dry Battery Solution

GENERAL DESCRIPTION

HM5705 is one SOC that it integrates one High precision current battery charger、 Buck converter、 Anti-backflow PMOS in only DFN3x3-10 package.

This SOC can output 1.5Vout 2A with Li-Battery Input and also can charge with 700mA current.

It only need few components and can reduce the BOM area and BOM cost.

FEATURES

- 2.5V to 5.5V Input Range
- 2A Output Capability
- High Efficiency up to 95%
- Low Quiescent Current 30uA
- Fixed Output Voltage 1.5V

- 1.5MHz Constant Frequency Operation
- Under Voltage Lockout, Over Current, and Thermal Protection
- 700mA charging Capability
- Constant-Current/Constant-Voltage Operation with Thermal Regulation to Maximize Charge Rate Without Risk of Overheating
- Preset 4.2V Charge Voltage with $\pm 1\%$ Accuracy
- Integrated Anti-backflow PMOS
- C/10 Charge Termination
- 2.9V Trickle Charge Threshold
- Operating Temperature: -40°C to $+85^{\circ}\text{C}$
- Available in very tiny DFN2X3-8 Package
- RoHS Compliant and 100% Lead(Pb)-Free

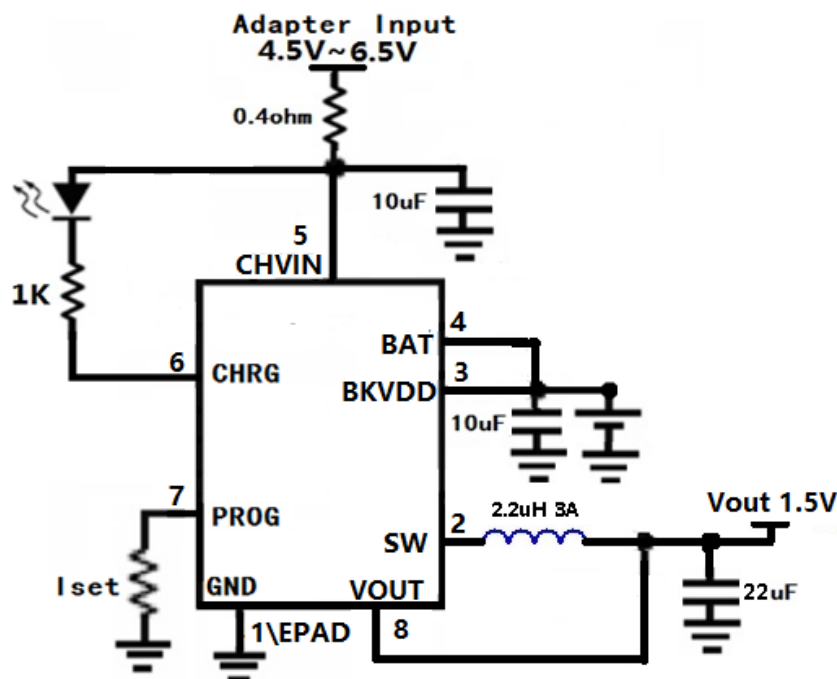

Figure 1. Typical Application Circuit1

ORDERING INFORMATION

PART NUMBER	TEMP RANGE	VIN LI-BATTERY	OUTPUT VOLTAGE (V)	ISET (MAX)	VBAT	MARK	PACKAGE	PINS
HM5705	-40°C to 85°C	2.5V~5.5V	1.5V	700mA	4.2V	HM5705YW	DFN2x3	8

Note: "YW" is manufacture date code, "Y" means the year, "W" means the week

PIN CONFIGURATION

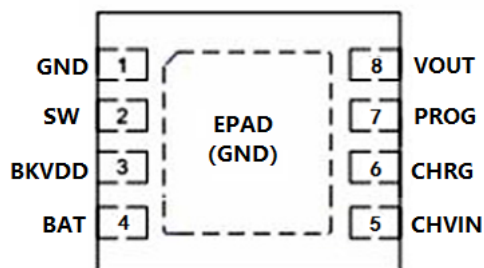

Figure 2. PIN Configuration

PIN DESCRIPTION

PIN NUMBER	PIN NAME	PIN DESCRIPTION
1,EPAD	GND	Ground\ EPAD , Please connect with mass metal
2	SW	Buck regulator Switch Pin
3	BKVDD	Power Supply of Buck regulator, Normally connect with BAT+ and BKEN, Need a 10uF capacitor bypass.
4	BAT	Li-Battery's Positive Pole, Need a 10uF capacitor bypass.
5	CHVIN	The Adapter input, Need a 10uF capacitor bypass.
6	CHRG	Open-Drain Charge Status Output. Charge status indicated.
7	PROG	Charge Current Program, Charge Current Monitor and Shutdown Pin.
8	VOUT	Feedback Input. VOUT senses the output voltage to regulator that voltage at 1.5V

ABSOLUTE MAXIMUM RATINGS

(Note: Do not exceed these limits to prevent damage to the device. Exposure to absolute maximum rating conditions for long periods may affect device reliability.)

PARAMETER	VALUE	UNIT
Supply Voltage CHVIN	-0.3V to +7V	V
Other Pins	-0.3V~5.5V	V
Operating Ambient Temperature	-40 to 85	°C
Maximum Junction Temperature	150	°C
Storage Temperature	-55 to 150	°C
Lead Temperature (Soldering, 10 sec)	300	°C

ELECTRICAL CHARACTERISTICS

(T_A= 25°C unless otherwise specified)

PARAMETER	SYMBOL	TEST CONDITIONS	MIN	TYP	MAX	UNIT
Input Voltage Range	V _{bat}		2.5		5.5	V
UVLO Threshold	V _{UVLO}	V _{HYSTERESIS} =100mV	2.6	2.8	3.0	V
Quiescent Current	I _q	V _{bat} =3.6V V _{OUT} =1.6V I _{Load} =0		20	35	μA
Operating Supply Current	I _{SUPPLY}	V _{bat} =3.6V V _{OUT} =1.4V I _{Load} =0		150	400	uA
Regulated Output Voltage	V _{OUT}	V _{OUT} =1.5V; I _{OUT} =100mA	1.455	1.5	1.545	V
Peak Inductor Current	I _{PEAK}			4		A
Oscillator Frequency	F _{OSC}	V _{bat} =3.6V V _{OUT} =1.5V I _{OUT} =1A	1.2	1.5	1.8	MHz
R _{ds} (ON) of P-channel FET		I _{sw} =100mA		0.15	0.3	Ohm
R _{ds} (ON) of N-channel FET		I _{sw} =100mA		0.11	0.2	Ohm
Input Voltage Range	CHVIN		4.25		6.5	V
Input supply current	I _{cc}	Charge mode, RPROG =10K		350	2000	uA
		Standby mode		150	500	uA
		Shutdown mode (RPROG not connected, CHVIN< Vbat or CHVIN< Vuv)		50	100	uA

BAT pin Current Input supply current	I _{bat}	R _{PROG} =2k,Current mode	280	310	340	mA
		R _{PROG} =10k,Current mode	50	60	70	mA
		Standby mode, V _{bat} =4.3V	0	-2.5	-6	uA
		Shutdown mode		1	2.5	uA
		Sleep mode, V _{cc} =0V		0.3	2.5	uA
Regulated Charge Voltage	V _{float}	I _{charge} = 28mA R _{prog} =10k	4.158	4.2	4.242	V
PROG pin Voltage	V _{prog}	R _{PROG} =10k, Current mode	0.9	1.0	1.1	V
Trickle charge current	I _{trikl}	V _{bat} =2V, R _{prog} =2k	28	31	34	mA
Trickle charge Threshold Voltage	V _{trikl}	R _{PROG} =10K , V _{bat} Rising	2.7	2.9	3.1	V
CHRG pin Output low voltage	V _{chrg}	I _{chrg} =5mA		0.35	0.6	V

FUNCTIONAL DESCRIPTION

NORMAL OPERATION

HM5705 integrates one High precision current battery charger, Buck converter and anti-backflow PMOS in only DFN2x3-8 package.

In Buck normal operation the high-side MOSFET turns on each cycle and remains on until the current comparator turns it off. At this point the low-side MOSFET turns on and remains on until either the end of the switching cycle or until the inductor current approaches zero. The error amplifier adjusts the current comparator's threshold as necessary in order to ensure that the output remains in regulation.

In Battery Charger operation, The charge current is programmed by connecting a 1% resistor, RPROG, to ground. When charging in constant-current mode, this pin serves to 1V. In all modes, the voltage on this pin can be used to measure the charge current using the following formula:

$$IBAT = (V_{PROG}/R_{PROG}) \times 625.$$

The PROG pin can also be used to shut down the charger. Disconnecting the program resistor from ground allows a 3uA current to pull the PROG pin high. When it reaches the 1.21V shutdown threshold voltage, the charger enters shutdown mode, charging stops and the input supply current drops to 50uA. This pin is also clamped to approximately 2.4V. Driving this pin to voltages beyond the clamp voltage will draw currents as high as 1.5mA. Reconnecting RPROG to ground will return the charger to normal operation.

When the battery is charging, the CHRГ pin is pulled low by an internal N-channel MOSFET. When the charge cycle is completed, CHRГ pin will be in a high-impedance state; When the battery charge is complete, STDBY pulled low by internal switches, indicating the completion of charging. In addition, STDBY pin will be in a high-impedance state

When adapter is plug in, integrated anti-backflow PMOS can insulate buck converter and battery charger to avoid adapter input to pass to battery through body-diode of buck converter.

APPLICATION INFORMATION

INDUCTOR SELECTION

In normal operation, the inductor maintains continuous current to the output. The inductor current has a ripple that is dependent on the inductance value. The high inductance reduces the ripple current. In general, select the inductance by the following equation:

$$L = \frac{V_{OUT} \times (V_{IN} - V_{OUT})}{V_{IN} \cdot f \cdot \Delta I}$$

Where V_{OUT} is the output voltage, V_{IN} is the input voltage, f is the switch frequency, and ΔI is the peak-to-peak inductor ripple current. Typically, choose ΔI as the 30% of the maximum output current.

Manufacturer	Part Number	Inductance (uH)	DRC max (Ohms)	Dimensions L*W*H (mm3)
Murata	LQH5BPN	1	0.019	5*5*2
		2.2	0.030	
	LQH44PN	1	0.036	4*4*1.7
		2.2	0.049	
WURTH	74437324022	2.2	0.061	4.4*4.05

Table 1. Recommend Surface Mount Inductors

INPUT CAPACITOR SELECTION

The input capacitor reduces input voltage ripple to the converter, low ESR ceramic capacitor is highly recommended. For most applications, a 10uF or 22uF capacitor is used. The input capacitor should be placed as close as possible to VIN and GND.

OUTPUT CAPACITOR SELECTION

A low ESR output capacitor is required in order to maintain low output voltage ripple. In the case of ceramic output capacitors, capacitor ESR is very small and does not contribute to the ripple, so a lower capacitance value is acceptable when ceramic capacitors are used. A 22uF ceramic output capacitor is suitable for most applications.

PCB LAYOUT GUIDE

- 1, The input/output capacitors should be placed very close to the device and ground, to keep the loop resistance very low and the switching loop very small.
- 2, All ground connection must be tied together. It is desirable to maximize the PCB copper area connecting to GND/EPAD pin to achieve the best thermal and noise performance. If the board space allowed, a ground plane is highly desirable
- 3, The Vout pin connection should be made as close to the load as possible so that the voltage at the load is the expected regulated value.
- 4, The Vout pin connection must NOT be adjacent to the SW net on the PCB layout to avoid the noise problem
- 4, The switch node connection should be low resistance to reduce power losses.

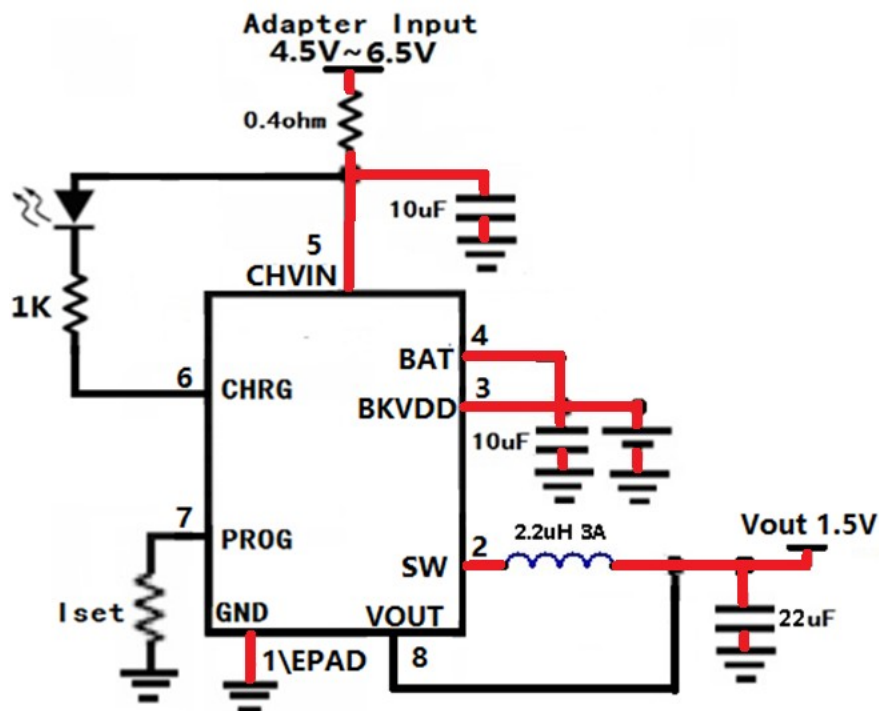

BIG CURRENT CIRCUIT(RED LINES)

TYPICAL PERFORMANCE CHARACTERISTICS

(VBAT=4V, L=2.2uH, CIN=10uF, COUT=22uF, CHVIN=5V, if not mentioned)

Efficiency vs. Output Current

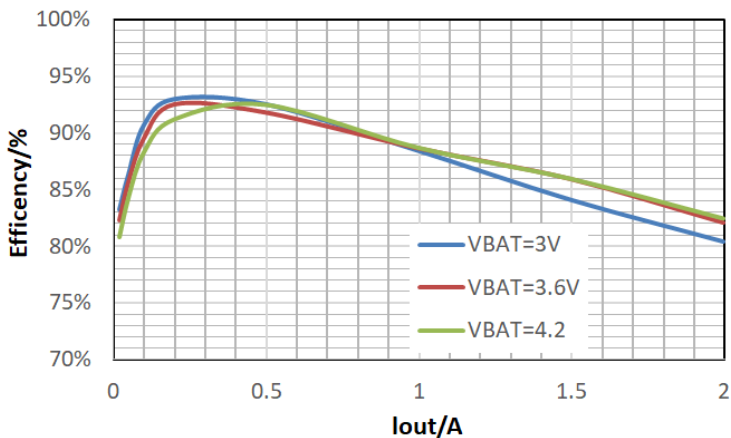

Battery charger curve

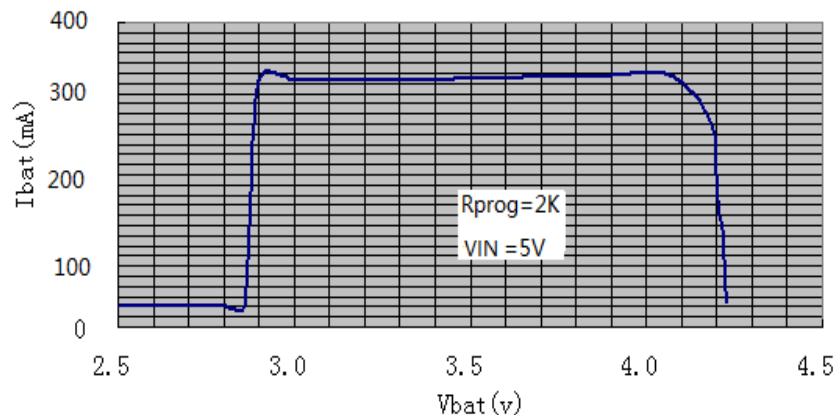

STEADY STATE WAVEFORM

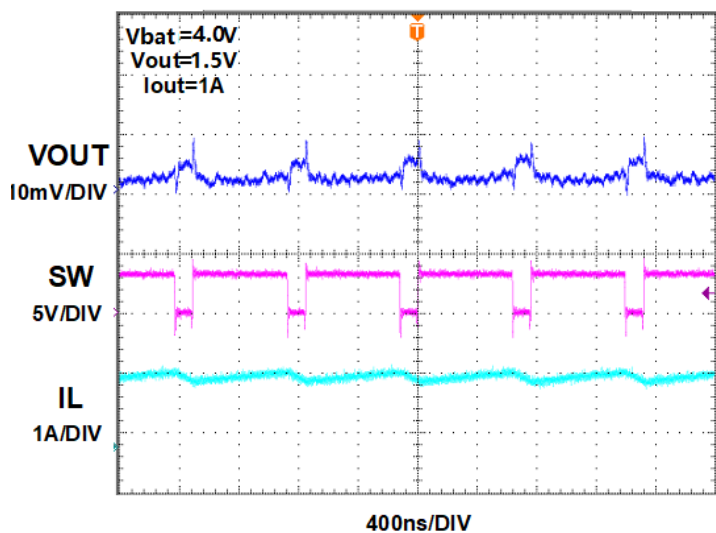

STEADY STATE WAVEFORM

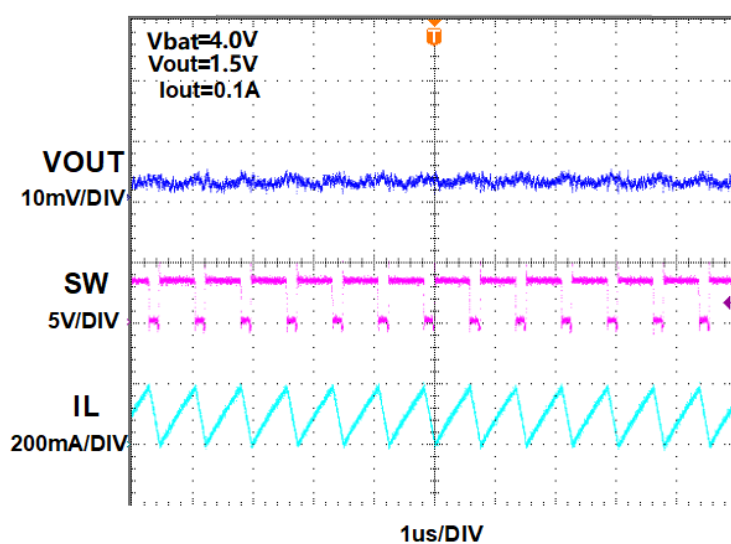

Transient Waveform(Iout=0.15A-1.5A)

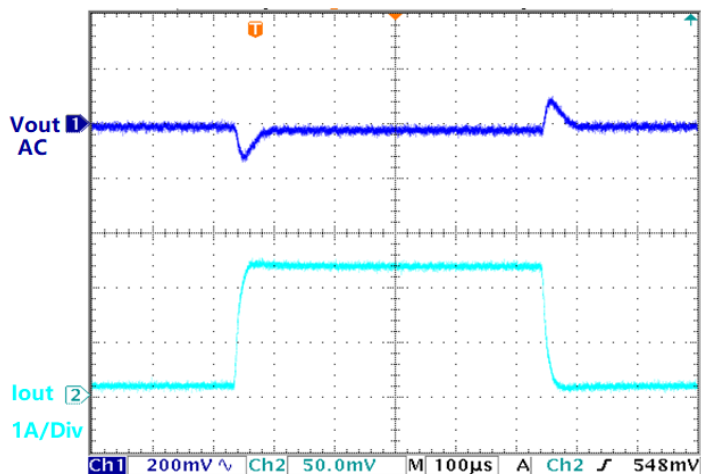

PACKAGE OUTLINE

DFN2X3X0.55-8L PACKAGE OUTLINE AND DIMENSIONS

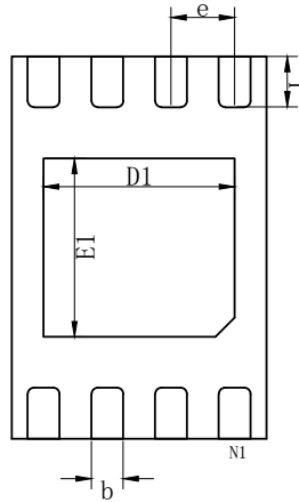
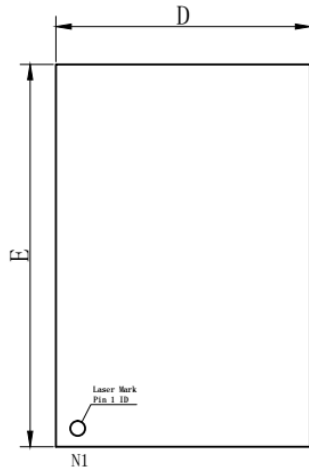

bottom view

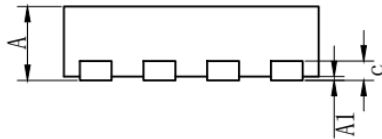

Dimension SYMBOL	MIN (mm)	TYP (mm)	MAX (mm)
A	0.50	0.55	0.60
A1	0.00	0.03	0.05
b	0.20	0.25	0.30
c	0.152REF		
D	1.95	2.00	2.05
e	0.50TYP		
E	2.95	3.00	3.05
E1	1.30	1.40	1.50
D1	1.40	1.50	1.60
L	0.35	0.40	0.45