

30V 2A 500KHz Synchronous Step-Down Regulator

Features

- Wide 4V to 30V Operating Input Range
- 2A Continuous Output Current
- Fixed 500KHz Switching Frequency
- No Schottky Diode Required
- Short Protection with Hiccup-Mode
- Built-in Over Current Limit
- Built-in Over Voltage Protection
- Internal Soft start
- Output Adjustable from 0.6V
- Integrated internal compensation
- Thermal Shutdown
- Available in SOT23-6 Package
- -40°C to +85°C Temperature Range

Applications

- CCTV Camera
- Flat-Panel Television and Monitor
- Battery Charger
- Distributed Power Systems

General Description

The RY8320 is a high frequency, synchronous, rectified, step-down, switch-mode converter with internal power MOSFETs. It offers a very compact solution to achieve a3A peak output current over a wide input supply range, with excellent load and line regulation.

The RY8320 requires a minimal number of readily available, external components and is available in a space saving SOT23-6 package.

Typical Application Circuit

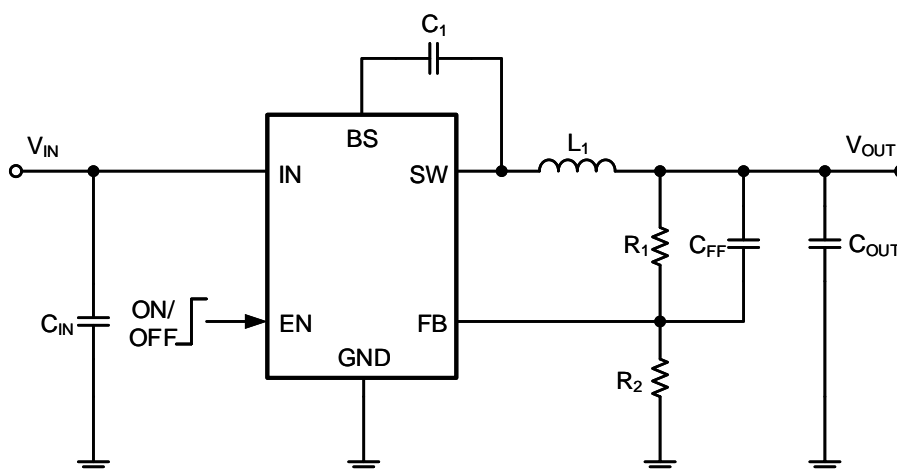
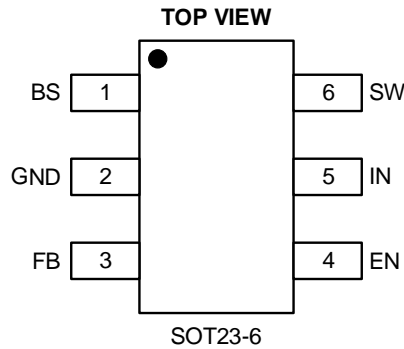

Figure 1. Basic Application Circuit

30V 2A 500KHz Synchronous Step-Down Regulator

Pin Description

Pin Configuration



Top Marking: GDYLL (device code: GD, Y=year code, LL= lot number code)

Pin Description

Pin	Name	Function
1	BS	Bootstrap. A capacitor connected between SW and BST pins is required to form a floating supply across the high-side switch driver.
2	GND	GROUND Pin
3	FB	Adjustable Version Feedback input. Connect FB to the center point of the external resistor divider
4	EN	Drive this pin to a logic-high to enable the IC. Drive to a logic-low to disable the IC and enter micro-power shutdown mode.
5	IN	Power Supply Pin
6	SW	Switching Pin

Order Information

Marking	Part No.	Model	Description	Package	MOQ
GDYLL	70301510	RY8320	RY8320 Buck, 4-30V, 2.0A, 500KHz, VFB 0.6V, SOT23-6	SOT23-6	3000PCS

30V 2A 500KHz Synchronous Step-Down Regulator

Absolute Maximum Ratings

V _{in} , EN, Voltage	-0.3V to 36V	SW Voltage	-0.3V to (V _{IN} +0.5V)
Operating Temperature Range	-40°C to +85°C	Storage Temperature Range	-65°C to 150°C
FB Voltages	-0.3 to 6V	BS Voltage	(V _{sw} -0.3) to (V _{sw} +5V)
Lead Temperature (Soldering, 10s)	+300°C	ESD (Machine Made) MM.....	200V
Thermal Resistance (θ _{JA})	230 °C/W	ESD (Human Body Made) HMB.....	2KV
Thermal Resistance (θ _{JC})	130 °C/W		

Note1: Exceeding these ratings may damage the device.

Note2: The device is not guaranteed to function outside of its operating conditions.

Electrical Characteristics

(V_{IN}=12V, V_{OUT}=5V, T_A = 25°C, unless otherwise noted.)

Parameter	Test Conditions	Min	Typ	Max	Unit
Input Voltage Range		4		30	V
Supply Current in Operation	V _{EN} =3.0V, V _{FB} =1.1V		0.4	0.6	mA
Supply Current in Shutdown	V _{EN} =0 or EN = GND			1	μA
Regulated Feedback Voltage	T _A = 25°C, 4V ≤ V _{IN} ≤ 18V	0.588	0.6	0.612	V
High-Side Switch On-Resistance			120		mΩ
Low-Side Switch On-Resistance			90		mΩ
High-Side Switch Leakage Current	V _{EN} =0V, V _{SW} =12V			1	uA
Upper Switch Current Limit	Minimum Duty Cycle		3		A
Oscillation Frequency			0.5		MHz
Maximum Duty Cycle	V _{FB} =0.6V			93	%
Minimum On-Time			60		nS
Minimum Off-Time			140		nS
Soft Start				1.2	mS
Thermal Shutdown			160		°C
Thermal Hysteresis			20		°C

Note1: 100% production test at +25°C. Specifications over the temperature range are guaranteed by design and characterization.

Note2: Dynamic supply current is higher due to the gate charge being delivered at the switching frequency.

30V 2A 500KHz Synchronous Step-Down Regulator

Over Current Protection & Hiccup

The RY8320 has cycle-by-cycle over current limit when the inductor current peak value exceeds the set current limit threshold. Meanwhile, output voltage starts to drop until FB is below the Under-Voltage (UV) threshold, typically 25% below the reference. Once a UV is triggered, the RY8320 enters hiccup mode to periodically restart the part. This protection mode is especially useful when the output is dead-short to ground. The average short circuit current is greatly reduced to alleviate the thermal issue and to protect the regulator. The RY8320 exits the hiccup mode once the over current condition is removed.

Startup and Shutdown

If both VIN and EN are higher than their appropriate thresholds, the chip starts. The reference block starts first, generating stable reference voltage and currents, and then the internal regulator is enabled. The regulator provides stable supply for the remaining circuitries. Three events can shut down the chip: EN low, VIN low and thermal shutdown. In the shutdown procedure, the signaling path is first blocked to avoid any fault triggering. The COMP voltage and the internal supply rail are then pulled down. The floating driver is not subject to this shutdown command.

Applications Information

Setting the Output Voltage

RY8320 require an input capacitor, an output capacitor and an inductor. These components are critical to the performance of the device. RY8320 are internally compensated and do not require external components to achieve stable operation. The output voltage can be programmed by resistor divider.

$$V_{OUT} = V_{FEEDBACK} \times \frac{R1 + R2}{R2}$$

OUTPUT	R1(KΩ)	R2 (KΩ)	L1(MIN)	L1(TYP)	L1(MAX)	CIN	COUT
1.05V	51	68	2.2 uH	2.2 uH	4.7 uH	20-47uF	20-68uF
1.2V	51	51	2.2 uH	2.2 uH	4.7 uH	20-47uF	20-68uF
1.5V	51	33	2.2 uH	2.2 uH	4.7 uH	20-47uF	20-68uF
3.3V	51	11.3	2.2 uH	2.2 uH	4.7 uH	20-47uF	20-68uF
5.0V	51	6.8	3.3 uH	4.7 uH	6.8 uH	20-47uF	20-68uF

30V 2A 500KHz Synchronous Step-Down Regulator

Selecting the Inductor

The recommended inductor values are shown in the Application Diagram. It is important to guarantee the inductor core does not saturate during any foreseeable operational situation. The inductor should be rated to handle the peak load current plus the ripple current: Care should be taken when reviewing the different saturation current ratings that are specified by different manufacturers. Saturation current ratings are typically specified at 25°C, so ratings at maximum ambient temperature of the application should be requested from the manufacturer.

$$L = \frac{V_{out} \times (V_{in} - V_{out})}{V_{in} \times \Delta I_L \times f_{OSC}}$$

Where ΔI_L is the inductor ripple current. Choose inductor ripple current to be approximately 30% of the maximum load current, 3A. The maximum inductor peak current is:

$$I_{L(MAX)} = I_{LOAD} + \frac{\Delta I_L}{2}$$

Under light load conditions below 100mA, larger inductance is recommended for improved efficiency.

Selecting the Output Capacitor

Special attention should be paid when selecting these components. The DC bias of these capacitors can result in a capacitance value that falls below the minimum value given in the recommended capacitor specifications table.

The ceramic capacitor's actual capacitance can vary with temperature. The capacitor type X7R, which operates over a temperature range of -55°C to +125°C, will only vary the capacitance to within $\pm 15\%$. The capacitor type X5R has a similar tolerance over a reduced temperature range of -55°C to +85°C. Many large value ceramic capacitors, larger than 1 μ F are manufactured with Z5U or Y5V temperature characteristics. Their capacitance can drop by more than 50% as the temperature varies from 25°C to 85°C. Therefore X5R or X7R is recommended over Z5U and Y5V in applications where the ambient temperature will change significantly above or below 25°C.

Tantalum capacitors are less desirable than ceramic for use as output capacitors because they are more expensive when comparing equivalent capacitance and voltage ratings in the 0.47 μ F to 44 μ F range. Another important consideration is that tantalum capacitors have higher ESR values than equivalent size ceramics. This means that while it may be possible to find a tantalum capacitor with an ESR value within the stable range, it would have to be larger in capacitance (which means bigger and more costly) than a ceramic capacitor with the same ESR value. It should also be noted that the ESR of a typical tantalum will increase about 2:1 as the temperature goes from 25°C down to -40°C, so some guard band must be allowed.

PC Board Layout Consideration

PCB layout is very important to achieve stable operation. It is highly recommended to duplicate EVB layout for optimum performance. If change is necessary, please follow these guidelines and take Figure 4 for reference.

1. Keep the path of switching current short and minimize the loop area formed by Input capacitor, high-side MOSFET and low-side MOSFET.
2. Bypass ceramic capacitors are suggested to be put close to the Vin Pin.
3. Ensure all feedback connections are short and direct. Place the feedback resistors and compensation components as close to the chip as possible.
4. VOUT, SW away from sensitive analog areas such as FB.
5. Connect IN, SW, and especially GND respectively to a large copper area to cool the chip to improve thermal performance and long-term reliability.

30V 2A 500KHz Synchronous Step-Down Regulator

Package Description

SOT23-6

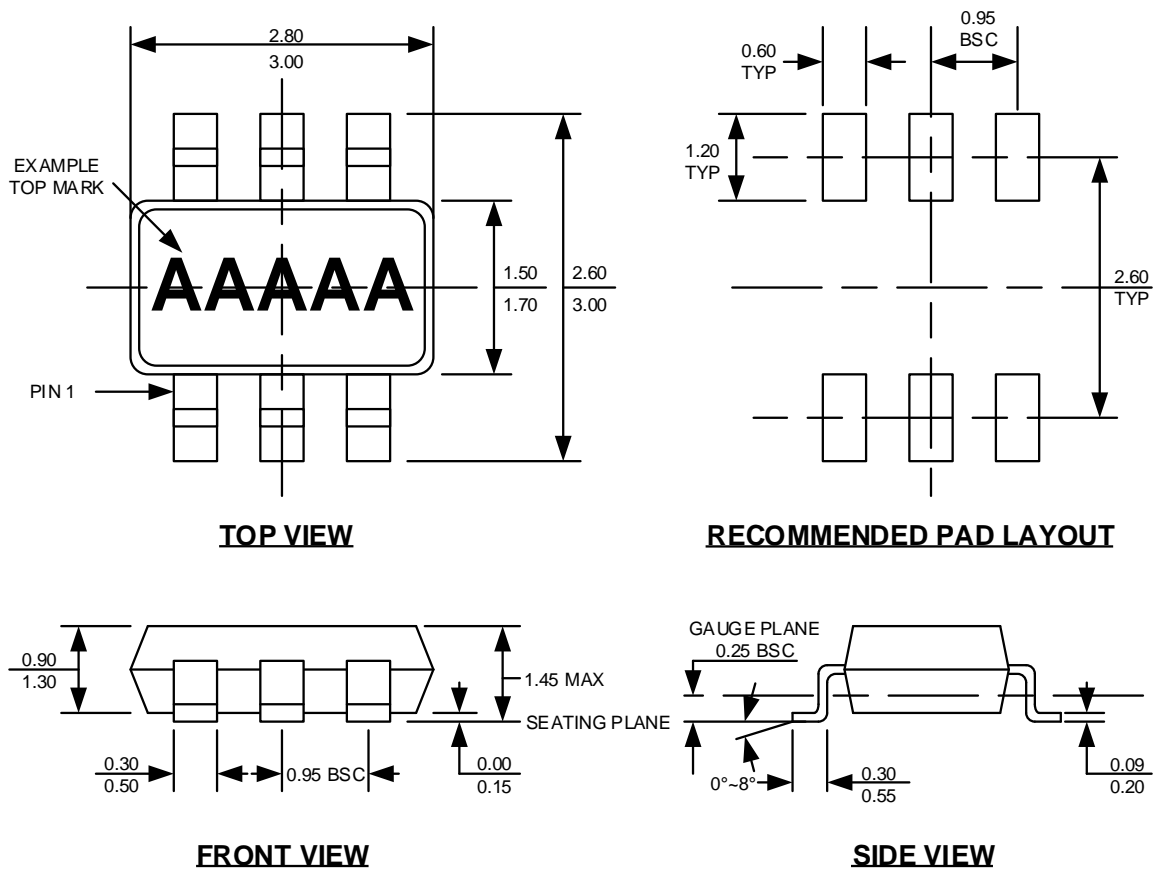

Note:

1. All dimensions are in millimeters.
2. Package length does not include mold flash, protrusion or gate burr.
3. Package width does not include flash or protrusion.
4. Lead coplanarity (bottom of leads after forming) shall be 0.10 millimeters max.
5. Pin 1 is lower left pin when reading top mark from left to right.