Standalone Li-Ion Switch Mode Battery Charger

Features

- Input Supply Range: 9V ~ 14V
- End-Charge-Current Detection Output
- Constant Switching Frequency for Minimum Noise
- Automatic Battery Recharge
- Automatic Shutdown When Input Supply is Removed
- Automatic Trickle Charging of Low Voltage Batteries
- Battery Temperature Sensing
- Stable with Ceramic Output Capacitor
- SOP-8L Package

Description

The HM8202 is a complete battery charger controller for two (8.4V) cells lithium-ion batteries. The HM8202 provides a small, simple and efficient solution to fast charge Li-ion battery. An external sense resistor sets the charge current with high accuracy.

An internal resistor divider and precision reference set the final float voltage to 8.4V. When the input supply is removed, the HM8202 automatically enters a low current sleep mode.

The HM8202 is available in the SOP-8L package.

Application

- Charging Docks
- Handheld Instruments
- Portable Computers

Typical Application Circuit

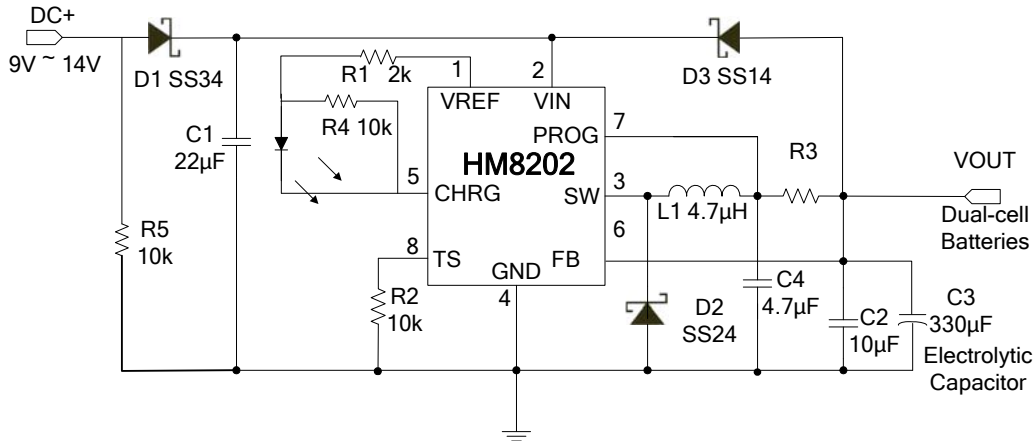

*The charge current can be set by $I_{OUT} = 0.11V/R3$.

Pin Assignment

| TOP VIEW | | PIN | NAME | FUNCTION |
|----------|---|-----|------|-------------------------------------|
| 8 | 7 | 1 | VREF | Voltage Reference to Drive LED |
| 6 | 5 | 2 | VIN | Input |
| | | 3 | SW | Switch Output |
| | | 4 | GND | Ground |
| | | 5 | CHRG | Open-Drain Charge Status for Output |
| | | 6 | FB | Feedback |
| | | 7 | PROG | Charge Current Program |
| | | 8 | TS | Temperature Sense |

Absolute Maximum Ratings (Note 1)

- Input Supply Voltage -0.3V ~ 16V
- CHRG Pin Voltage..... - 0.3V ~ 7V
- PROG Pin Voltage..... -0.3V ~ 16V
- SW Pin Voltage..... -0.3V ~ 16V
- SW Pin Current 4A
- Operating Temperature Range(Note 2) - 40°C ~ + 85°C
- Junction Temperature -40°C ~ + 125°C
- Storage Temperature Range - 65°C ~ + 150°C
- Lead Temperature (Soldering, 10 sec.) + 265°C

Note 1: Stresses listed as the above “Absolute Maximum Ratings” may cause permanent damage to the device. Exposure to absolute maximum rating conditions for extended periods may remain possibility to affect device reliability.

Note 2: The HM8202 is guaranteed to meet performance specifications from 0°C to 85°C. Specifications over the -40°C to 85°C operating temperature range are assured by design, characterization and correlation with statistical process controls.

Electrical Characteristics

Operating Conditions: $T_A=25^{\circ}\text{C}$, unless otherwise specified.

| SYMBOL | PARAMETER | CONDITIONS | MIN | TYP | MAX | UNITS |
|---|---------------------------------|---------------------------------------|-----|---------------------------|------|---------------|
| V_{IN} | Input Voltage Range | | 9 | | 14 | V |
| I_{SLEEP} | VIN Sleep Current | $V_{IN}=7V, V_{OUT}=7.22V$ | | 40 | | μA |
| I_{IN} | Input Supply Current | Current Mode | | 260 | | μA |
| F_{OSC} | Oscillator Frequency for Output | $V_{IN}=9V, V_{OUT}=7V, R3=0.1\Omega$ | | 0.78 | | MHz |
| EFFI | Efficiency for Output | $V_{IN}=9V, V_{OUT}=8V$ | | 95 | | % |
| | | $V_{IN}=12V, V_{OUT}=8V$ | | 93 | | % |
| Battery Voltage Regulation Constant-current Charge | | | | | | |
| $V_{O(REG)}$ | Output Voltage | | 8.3 | 8.44 | 8.54 | V |
| $V_{PROG}-V_{FB}$ | Voltage Regulation Threshold | | | 110 | | mV |
| Precharge Comparator | | | | | | |
| $V_{(MIN)}$ | Precharge Threshold | $V_{IN}=9V$ | | 5.5 | | V |
| Precharge Current Regulation | | | | | | |
| $I_{(PRECHG)}$ | Precharge Current Regulation | $R3=0.1\Omega, V_{IN}=9V$ | | 100 | | mA |
| V_{RCH} comparator (Battery Recharge Threshold) | | | | | | |
| $V_{(RCH)}$ | Recharge Threshold | $V_{IN}=12V$ | | $V_{O(REG)}-150\text{mV}$ | | V |
| V_{REF} Pin | | | | | | |
| V_{REF} | Constant-Current Charge | $V_{IN}=9V, V_{OUT}=7.8V$ | | 3.3 | | V |
| | Charge Termination | $V_{IN}=9V, V_{OUT}=8.5V$ | | 3.3 | | V |
| CHRG Pin | | | | | | |
| $V_{OL(CHRG)}$ | Output(low) Voltage | | | <0.15 | | V |
| TS Pin | | | | | | |
| $V_{TS-COLD}$ | TS Pin Threshold Voltage(Cold) | V_{TS} from Low to High | | 2.422 | | V |
| V_{TS-HOT} | TS Pin Threshold Voltage(Hot) | V_{TS} from High to Low | | 0.479 | | V |
| I_{TS} | TS Pin Output Current | | | 99.5 | | μA |

Typical Performance Characteristics

Operating Conditions: $T_A=25^{\circ}\text{C}$, unless otherwise specified.

Efficiency vs. Input Voltage

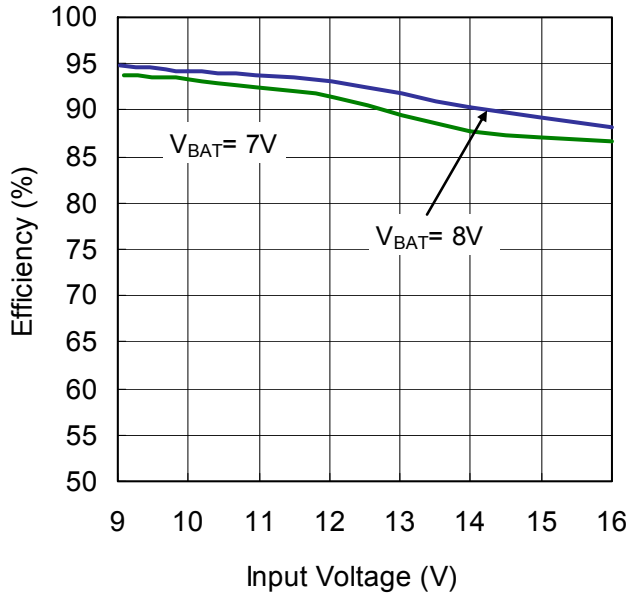

Recharge Voltage Offset from Full Charged Voltage vs. Input Voltage

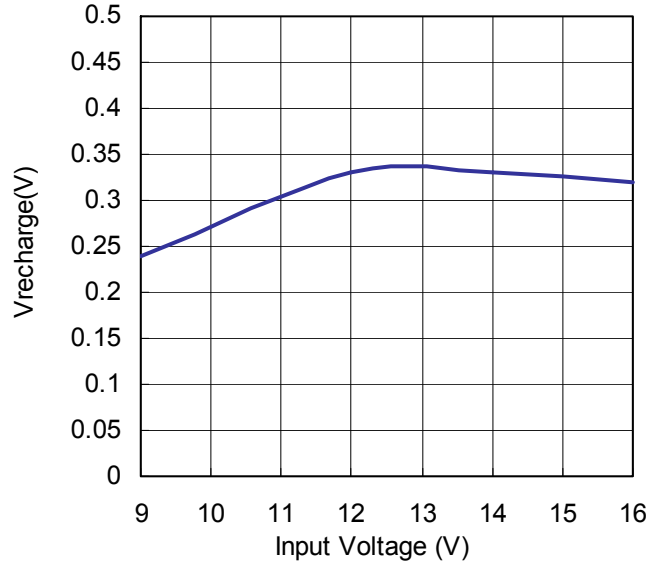

Supply Current vs. Supply Voltage

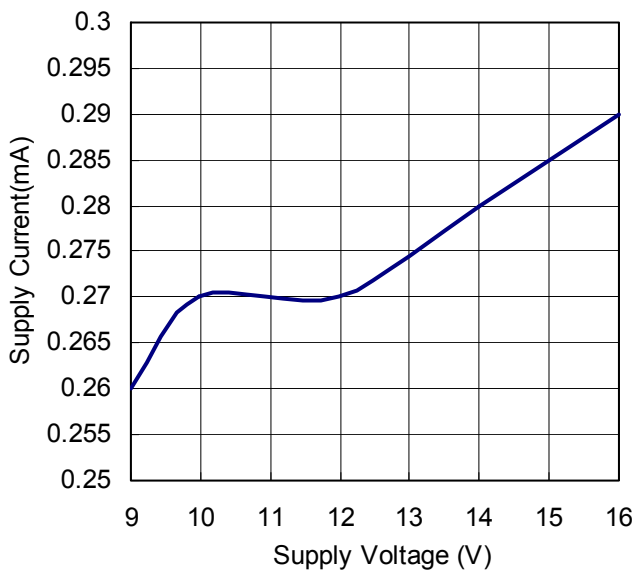

Oscillator Frequency vs. Supply Voltage ($V_{out}=8V$)

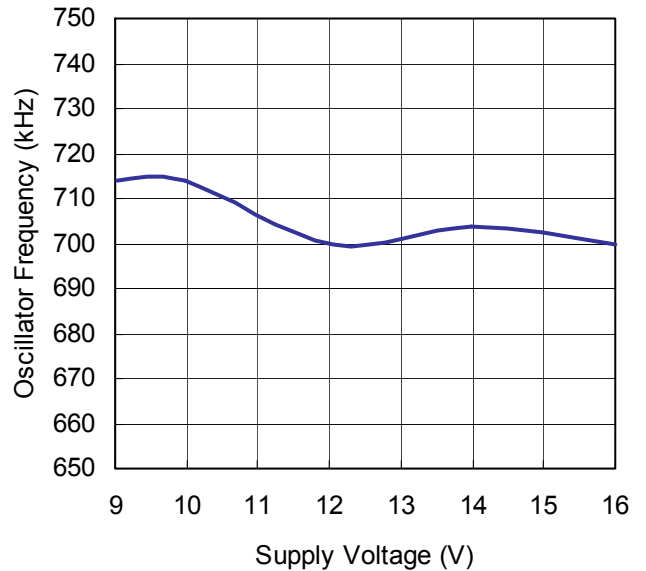

Pin Assignment

VREF (Pin 1): Voltage reference to drive LED.

VIN (Pin 2): Positive Input Supply Voltage. It provides power to the charger. VIN can range from 9V to 16V and should be bypassed with at least a 22 μ F capacitor.

SW (Pin 3): Switch Node Connection to inductor. This pin connects to the drain of the internal main power MOSFET switches.

GND (Pin 4): Ground.

CHRG (Pin 5): Open-Drain Charge Status Output. When the battery is charging, the CHRG pin is pulled low by an internal N-channel MOSFET. When the charge cycle is completed or reverse battery lockout / No AC is detected, CHRG is forced high impedance.

FB (Pin 6): Feedback Pin. Receive the feedback voltage from the output.

PROG (Pin 7): Charge Current Program. The output current is set by an external resistor according to the following formula: $I_{OUT} = 0.11V/R3$.

TS (Pin 8): Temperature Sense.

Application Information

Functional Description

The HM8202 is an advanced switch mode charger for two-cell Li-Ion applications. Refer to Operation Flow Chart (Figure 1) in this section.

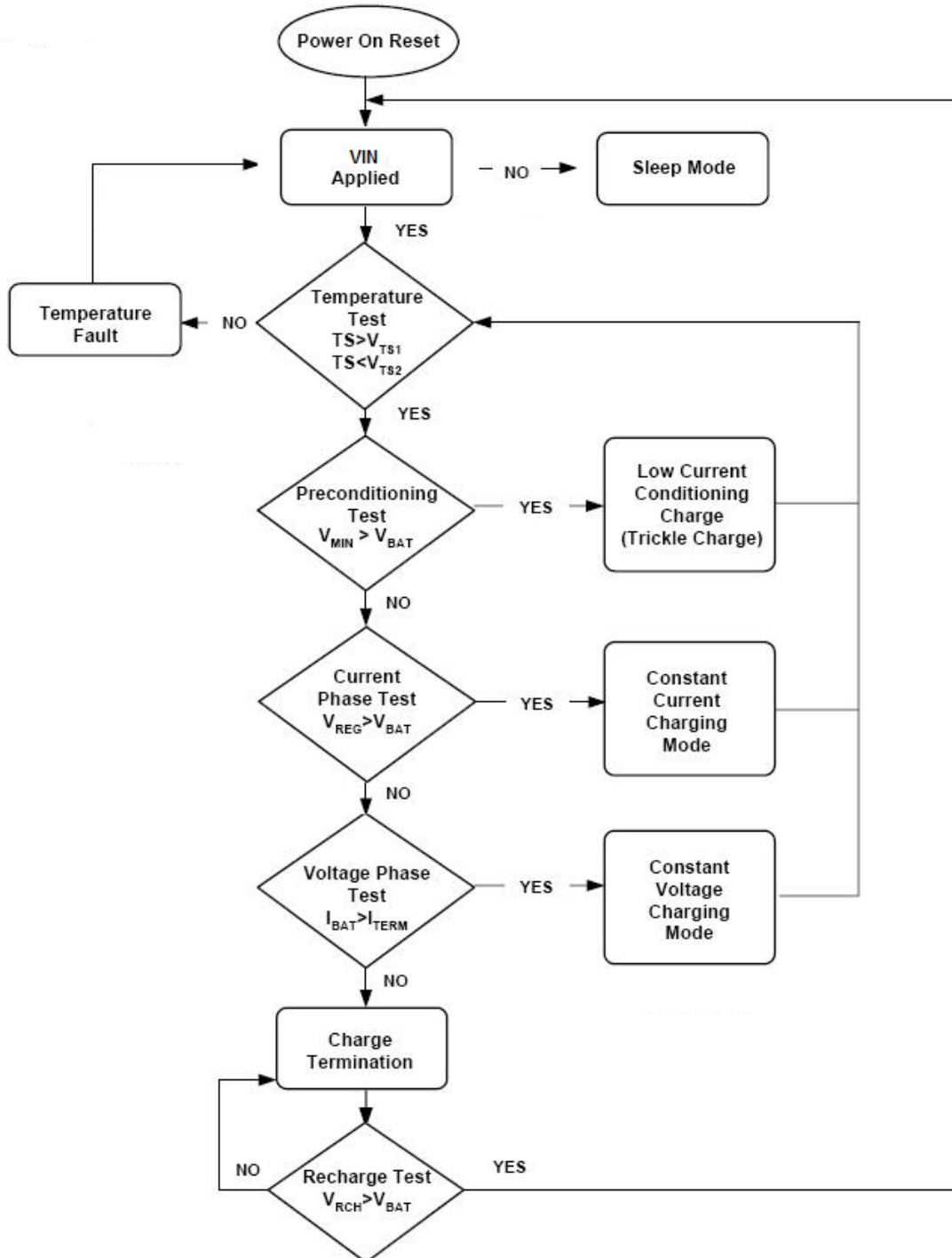

Figure1: Operation Flow Chart

Qualification and Precharge

When power is applied, the HM8202 starts a charge-cycle if a battery is already present or when a battery is inserted. Charge qualification is based on battery temperature and voltage.

The HM8202 suspends charge if the battery temperature is outside the V_{TS1} to V_{TS2} range and suspends charge until the battery temperature is within the allowed range. The HM8202 also checks the battery voltage. If the battery voltage is below the precharge threshold $V_{(MIN)}$, the HM8202 uses precharge to condition the battery. The conditioning charge rate $I_{(PRECHG)}$ is set at approximately 10% of the regulation current. The conditioning current also minimizes heat dissipation in the external pass-element during the initial stage of charge. See Figure 2 for a typical charge-profile.

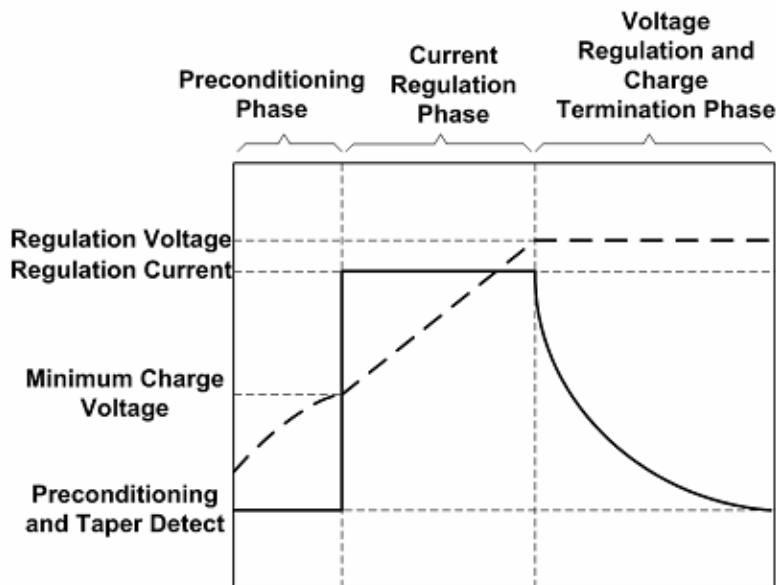

Figure 2: Typical Charge Profile

Current Regulation Phase

The HM8202 regulates current while the battery-pack voltage is less than the regulation voltage, $V_{O(REG)}$. The HM8202 monitors charge current by the voltage drop across a sense-resistor, R3, in series with the battery pack, and the resistor, R3, connected to the PROG pin. In order to set the current, first choose R3 based on the regulation threshold $V_{IREG} = V_{PROG} - V_{FB}$ across this resistor. The following formula calculates the value of the Sense resistor:

$$R3 = \frac{V_{IREG}}{I_{OCHARGE}}$$

Battery Voltage Regulation

The voltage regulation feedback occurs through the FB pin. This input is tied to the positive side of the battery pack. The HM8202 monitors the battery-pack voltage between the FB and GND pins. The HM8202 is offered in a fixed two-cell voltage version (8.4 V).

Charge Termination Recharge

The HM8202 monitors the charging current during the voltage-regulation phase. The HM8202 declares a done condition and terminates charge when the current drops to the charge termination threshold, I_{TERM} . A new charge cycle begins when the battery voltage falls below the V_{RCH} threshold.

Battery Temperature Monitoring

A negative temperature coefficient (NTC) thermistor located close to the battery pack can be used to monitor battery temperature and will not allow charging unless the battery temperature is within an acceptable range.

Connect a 10k Ω thermistor from the TS pin to ground. With the 99.5 μ A pull-up current source, the hot temperature voltage threshold is 479mV. For Cold temperature, the voltage threshold is set at 2.422V with 99.5 μ A of pull-up current. The charge cycle begins or resumes once the temperature is within the acceptable range.

Charge Status Indication

The HM8202 reports the status of the charge on the CHRG pin. The following table summarized the operation of the CHRG pin.

| Condition | CHRG pin |
|-----------------------------------|----------|
| Battery conditioning and charging | Low |
| Charge complete (done) | Hi-Z |
| Temperature fault or sleep mode | Hi-Z |

The CHRG pin can be used to drive a chip LED.

Low-Power Sleep Mode

When the input supply is disconnected, the charger automatically enters power-saving sleep mode. This feature prevents draining the battery pack during the absence of V_{IN} .

Input and Output Capacitors

Since the input capacitor is assumed to absorb all input switching ripple current in the converter, it must have an adequate ripple current rating. Worst-case RMS ripple current is approximately one-half of output charge current. Actual capacitance value is not critical. Solid tantalum capacitors have a high ripple current rating in a relatively small surface mount package, but caution must be used when tantalum capacitors are used for input bypass. High input surge currents can be created when the adapter is hot-plugged to the charger and solid tantalum capacitors have a known failure mechanism when subjected to very high turn-on surge currents. Selecting the highest possible voltage rating on the capacitor will minimize problems. Consult with the manufacturer before use.

The selection of output capacitor C_{OUT} is primarily determined by ESR required to improve ripple voltage and load transient. The output ripple ΔV_{OUT} is approximately bounded by:

$$\Delta V_{OUT} \leq \Delta I_L \left(ESR + \frac{1}{8f_{OSC}C_{OUT}} \right)$$

Since ΔI_L increases with input voltage, the output ripple is highest at maximum input voltage. Typically, once the ESR requirement is satisfied, the capacitance is adequate for filtering and has the necessary RMS current rating.

Switching ripple current splits between the battery and the output capacitor depending on the ESR of the output capacitor and the battery impedance. EMI considerations usually make it desirable to minimize ripple current in the battery leads. Ferrite beads or an inductor may be added to increase battery impedance at the 500kHz switching frequency. If the ESR of the output capacitor is 0.2Ω and the battery impedance is raised to 4Ω with a bead or inductor, only 5% of the current ripple will flow in the battery.

Board Layout Suggestions

When laying out the printed circuit board, the following considerations should be taken to ensure proper operation of the HM8202. To minimize radiation, pass transistor and the input bypass capacitor traces should be kept as short as possible. The PROG and SW pins should be connected directly to the sense resistor for best charge current accuracy. The ground pin also works as a heat sink, therefore use a generous amount of copper around the ground pin. This is especially important for high V_{IN} and/or high gate capacitance applications.

Packaging Information

SOP-8L Package Outline Dimension

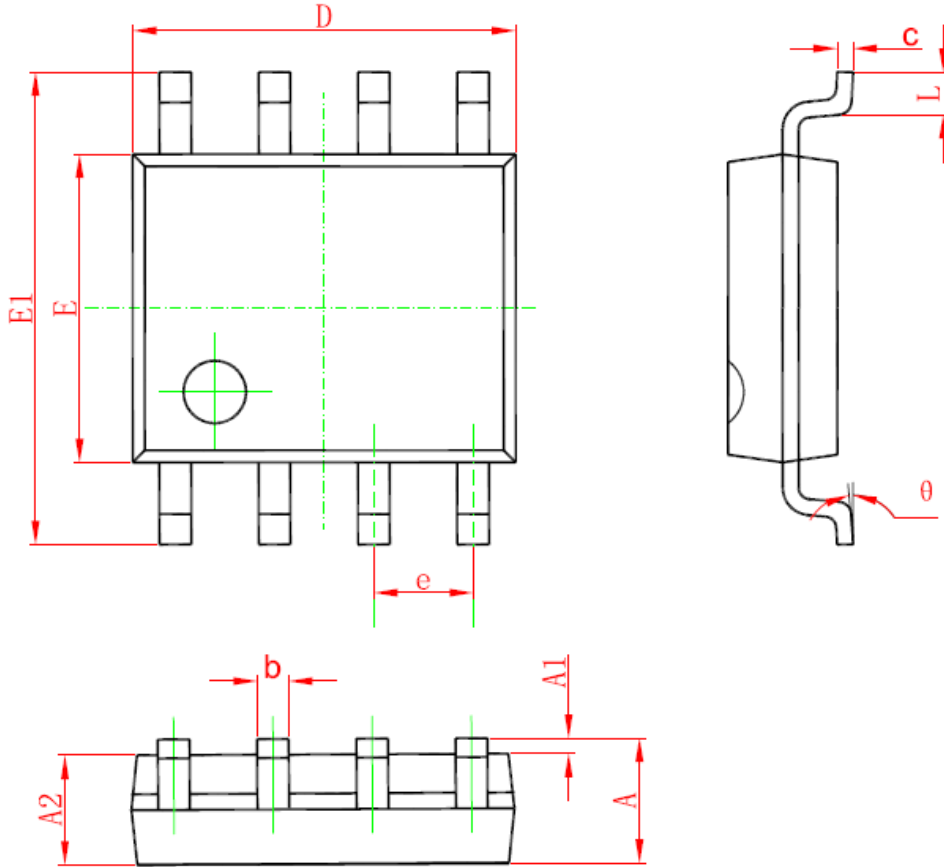

| Symbol | Dimensions In Millimeters | | Dimensions In Inches | |
|--------|---------------------------|-------|----------------------|-------|
| | Min | Max | Min | Max |
| A | 1.350 | 1.750 | 0.053 | 0.069 |
| A1 | 0.100 | 0.250 | 0.004 | 0.010 |
| A2 | 1.350 | 1.550 | 0.053 | 0.061 |
| b | 0.330 | 0.510 | 0.013 | 0.020 |
| c | 0.170 | 0.250 | 0.006 | 0.010 |
| D | 4.700 | 5.100 | 0.185 | 0.200 |
| E | 3.800 | 4.000 | 0.150 | 0.157 |
| E1 | 5.800 | 6.200 | 0.228 | 0.244 |
| e | 1.270(BSC) | | 0.050(BSC) | |
| L | 0.400 | 1.270 | 0.016 | 0.050 |
| θ | 0° | 8° | 0° | 8° |