

Features

- Micropower consumption
- 2.4V~5.5V power supply
- Chopper stabilized amplifier stage
- Open-drain output
- Switching for both polar of a magnet(Omnipolar)
- Very High Sensitivity Hall Sensor
- Package: SOT23, 3Pin SIP

Applications

- Solid State Switch
- Home appliances, Industrial
- Position Detection
- Proximity Switch
- Smart Meter

General Description

The HM90248 is fabricated from mixed signal CMOS technology. It internally includes an on-chip Hall voltage generator, a voltage regulator for operation with supply voltages of 2.4 to 5V, a sleep/awake logic for low power consumption, temperature compensation circuitry, small-signal amplifier, Hall sensor with dynamic offset cancellation system, Schmitt trigger and an open-drain output.

Either north or south poles of sufficient strength

will turn the sensor output on. The output will be turned off under no magnetic field. While the magnetic flux density (B) is larger than operating point (Bop), the output will be turned on (low), the output is held until B is lower than release point (Brp), and then turned off.

The total power consumption in normal operation is typically 10μW with a 2.7V power source. Operating temperature range of the HM90248 is from -40°C to 85°C.

Block Diagram

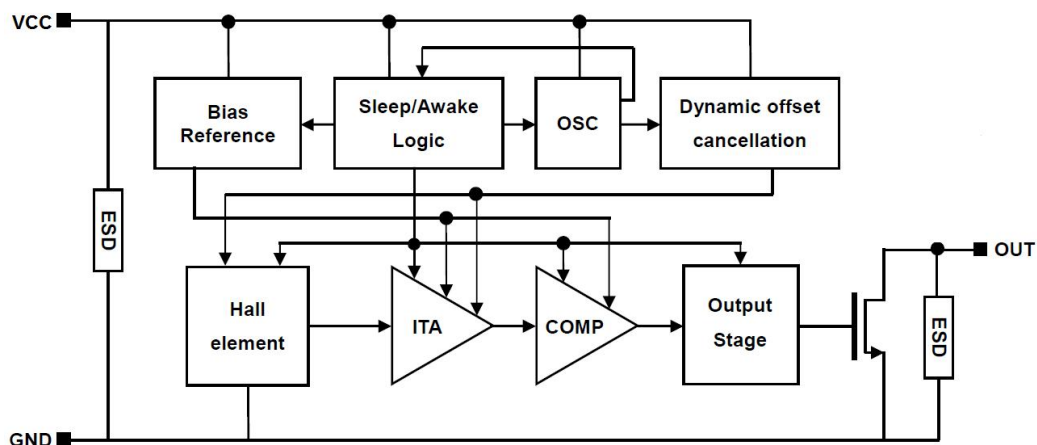

Fig 1

Pin Assignment

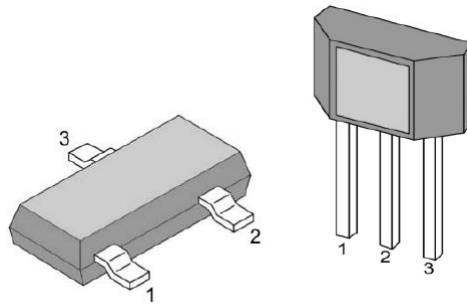

Fig2 SOT23 3Pin-SIP

Pin Description

SOT Pin Number	SIP Pin Number	Pin Name	Function
1	1	VCC	Supply Voltage
2	3	OUT	Open Drain Output
3	2	GND	Ground

Order Information

Part number	Description
HM90248	SOT-23 package, tape and reel packaging(3000pcs/bag),RoHS/Pb Free
HM90248	3Pin SIP package, bulk packaging (1000pcs/bag),RoHS/Pb Free

Absolute Maximum Ratings

Symbol	Parameter	Value	Unit	
V _{CC}	Supply Voltage	-0.3~5.5	V	
I _{DD}	Supply Current	5	mA	
B	Magnetic Flux Density	Unlimited	Gauss	
T _J	Operating Junction Temperature Range	-40 to 150	°C	
T _S	Storage Temperature	-65 to 150	°C	
PD	Power Dissipation	3Pin SIP	550	mW
		SOT23	230	mW

Note: Stresses greater than those listed under “Absolut Maximum Ratings” may cause permanent damage to the device. These are stress ratings only, and functional operation of these or any other conditions beyond those indicated under “Recommended Operating Conditions” is not implied. “Absolute Maximum Ratings” for extended period may affect device reliability.

Recommended Operating Conditions

(TA=25°C unless otherwise noted)

Parameter	Symbol	Min	Max	Unit
Supply Voltage	V _{CC}	2.4	5.0	V
Ambient Temperature	T _a	-40	85	°C

Electrical Characteristics

(V_{CC}=2.7V T_a=25°C, unless otherwise specified)

Symbol	Parameter	Test Conditions	Min.	Typ.	Max.	Unit
I _{CC}	Average Supply Current	V _{CC} =2.7V, Output Open	-	4	20	uA
I _{ON}	Supply current (operating mode)	V _{CC} =2.7V	-	1.2	-	mA
I _{ST}	Supply current (stand-by mode)	V _{CC} =2.7V	-	2.5	-	uA
V _{SAT}	Output Saturation Voltage	I _o =2mA, B>B _{op}	-	0.05	-	V
I _{OL}	Output Leakage Current	V _{out} =4.5V, B<B _{rp}	-	<0.1	1	u A
T _{awake}	Awake Time	V _{CC} =2.7V	-	40	-	us
T _{period}	Period	V _{CC} =2.7V	-	52	-	ms
ESD	Electro-Static Discharge	HBM		4		KV

Magnetic Characteristics

(V_{CC}=2.7V T_a=25°C, unless otherwise specified)

Characteristics	Symbol	Min	Typ	Max	Unit
Operating Point	B _{ops} (south pole to part marking side)	-	+40	+60	Gauss
	B _{opn} (north pole to part marking side)		-40	-60	
Releasing Point	B _{rps} (south pole to part marking side)	+15	+30	-	Gauss
	B _{rpn} (north pole to part marking side)	-15	-30	-	
Hysteresis	B _{hys} (B _{opx} - B _{rp} x)	-	10	-	Gauss

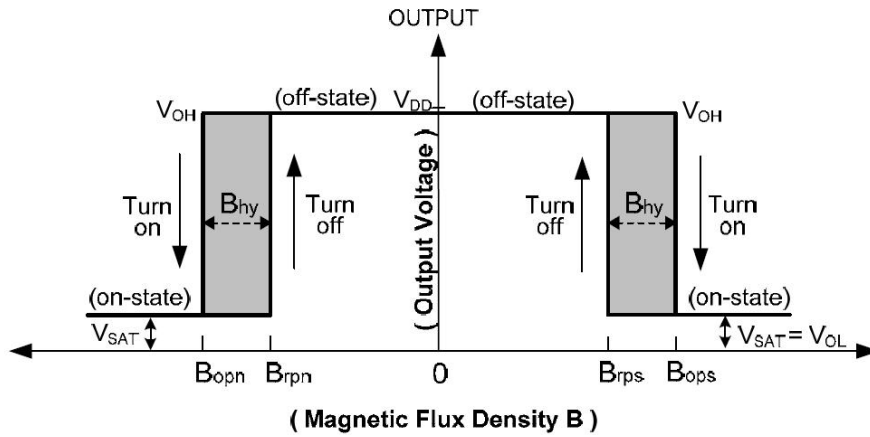

Fig 3

Typical Output Waveform

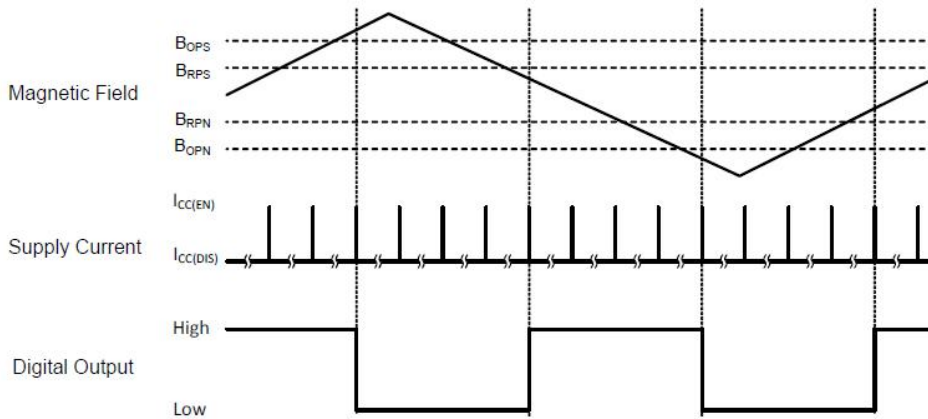
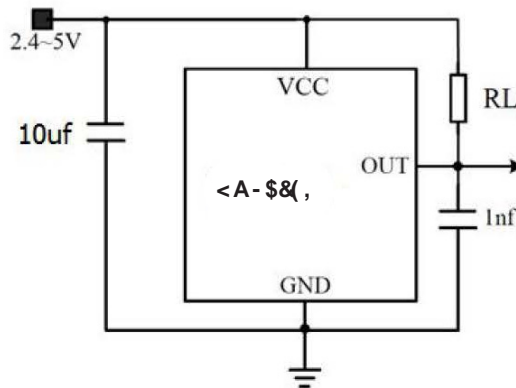

Fig 4

Application Circuits



Note: RL recommend 100KΩ

Fig 5

Typical Performance Characteristics

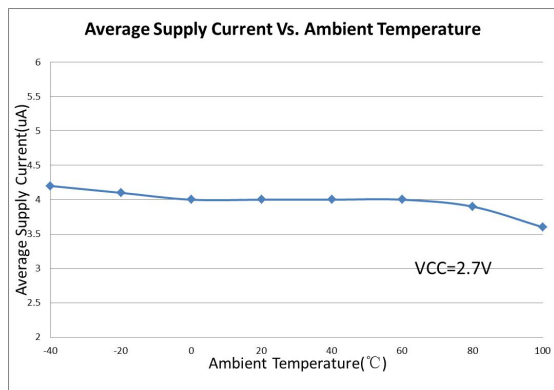

Fig6

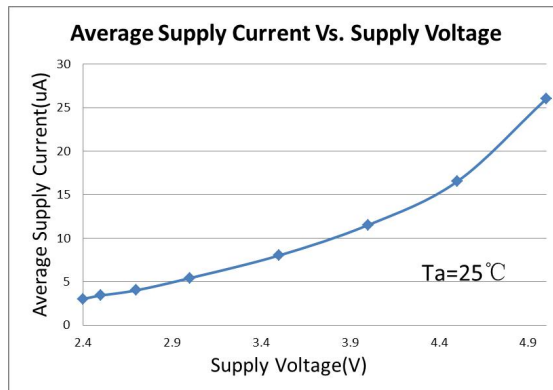
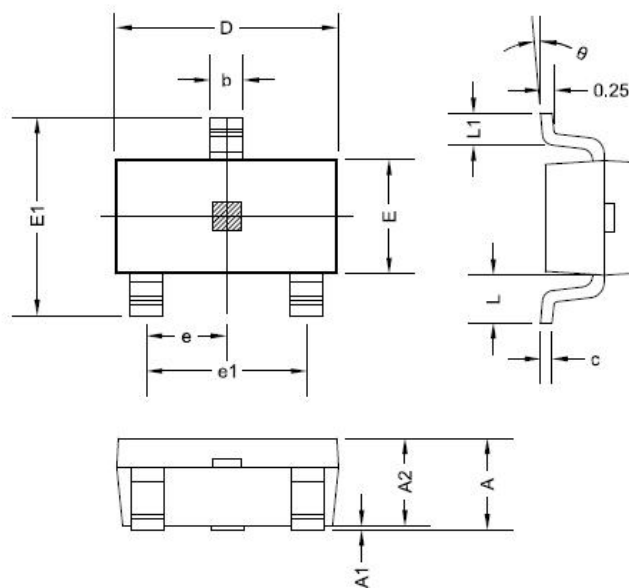

Fig7

Package Information

PACKAGE DESIGNATOR
 SOT23(HM90248)



Symbol	Dimensions in Millimeters		Dimensions in Inches	
	Min	Max	Min	Max
A	0.900	1.150	0.035	0.045
A1	0.000	0.100	0.000	0.004
A2	0.900	1.050	0.035	0.041
b	0.300	0.500	0.012	0.020
c	0.080	0.150	0.003	0.006
D	2.800	3.000	0.110	0.118
E	1.200	1.400	0.047	0.055
E1	2.250	2.550	0.089	0.100
e	0.950 TYP.		0.037 TYP.	
e1	1.800	2.000	0.071	0.079
L	0.550 REF.		0.022 REF.	
L1	0.300	0.500	0.012	0.020
θ	0°	8°	0°	8°

PACKAGE DESIGNATOR

3pin SIP(HM90248)

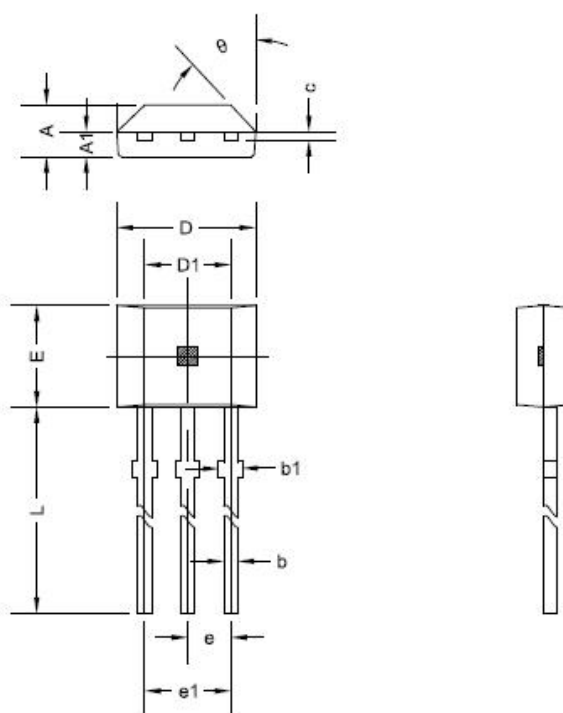

Symbol	Dimensions in Millimeters		Dimensions in Inches	
	Min	Max	Min	Max
A	1.420	1.620	0.056	0.064
A1	0.660	0.860	0.026	0.034
b	0.350	0.480	0.014	0.019
b1	0.400	0.550	0.016	0.022
C	0.360	0.510	0.014	0.020
D	3.900	4.200	0.154	0.165
D1	2.970	3.270	0.117	0.129
E	2.870	3.124	0.113	0.123
e	1.270 TYP.		0.050 TYP.	
e1	2.440	2.640	0.096	0.104
L	13.600	15.500	0.535	0.610
θ	45° TYP.		45° TYP.	