

150mΩ Power Distribution Switches

■ General Description

The HM9701A is an integrated 150mΩ power switch for self-powered and bus-powered Universal Series Bus (USB) applications. A built-in charge pump is used to drive the N-channel NMOSFET that is free of parasitic body diode to eliminate any reversed current flow across the switch when it is powered off. Its low quiescent supply current (23μA) and small package (SOT-23-5) is particularly suitable in battery-powered portable equipment.

Several protection functions include soft start to limit inrush current during plug-in, current limiting at 900mA or 600mA, and thermal shutdown to protect damage under over current conditions.

■ Features

- Wide Input Voltage Range: 2.2V ~ 6V
- 150mΩ (Typ.) High-Side NMOSFET (SOT- 23-5)
- 600Ma/900mA Current Limit
- Small SOT- 23-5 Package Minimizes Board Space
- Soft Start
- Thermal Protection
- Low 23 μA Supply Current

■ Applications

- Battery-Powered Equipment
- Motherboard USB Power Switch
- USB Device Power Switch
- Hot-Plug Power Supplies
- Battery-Charger Circuits

■ Typical Application Circuit

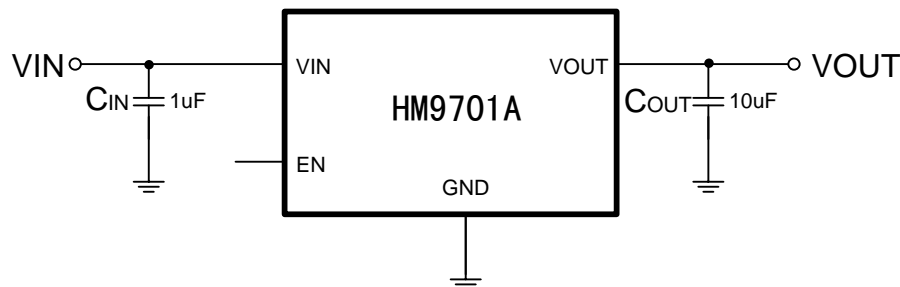

■ Package

- SOT-23-5

■ Pin Configuration

- Ordering information: **HM9701AB**

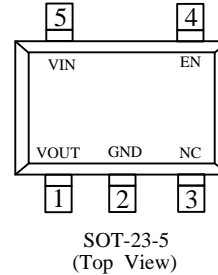

■ Product Name Description

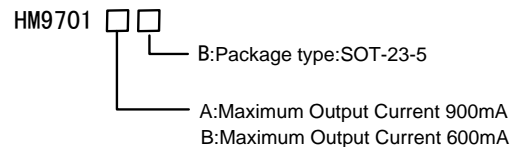

■ **Marking Rule**

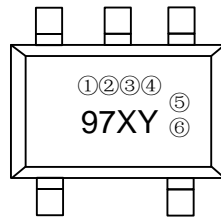

- 97----- HM9701
- X----- A represents the product HM9701AB
 B represents the product HM9701BB
- Y----- Production identified
- ①②③④⑤⑥-- Identification of quality control

■ **Block Diagram**

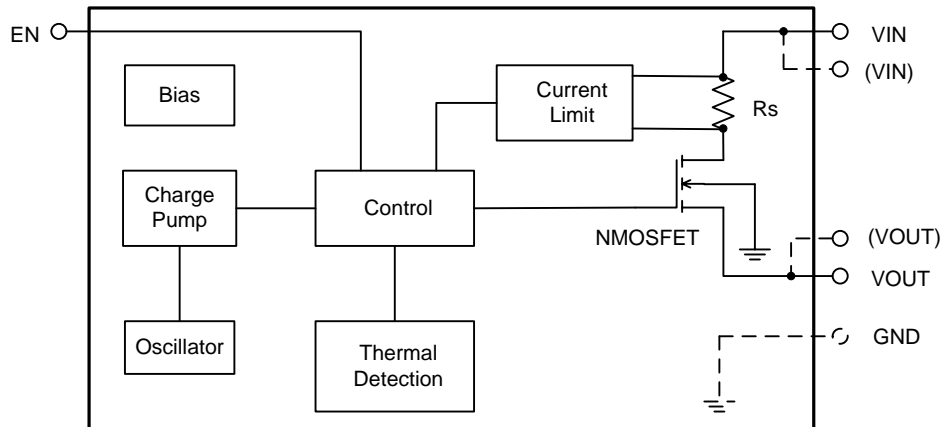

■ **Absolute Maximum Ratings**

Parameter	Symbol	Maximum Rating	Unit
Input Voltage	V_{DD}	7.0	V
EN to GND Voltage	V_{EN}	-0.3—7.0	V
Power Dissipation, $T_A=25^{\circ}C$ SOT-23-5	P_D	0.25	W
Thermal Resistance (SOT-23-5)	θ_{JA}	250	$^{\circ}C/W$
Lead Temperature (Soldering, 10 sec.)	—	260	$^{\circ}C$
Storage Temperature	T_{stg}	-65—150	$^{\circ}C$
Operating Ambient Temperature	—	-20—100	$^{\circ}C$
ESD Susceptibility	HBM	6000	V
	MM	600	V

■ **Electrical Characteristics**

($V_{IN} = 5V$, $C_{IN} = C_{OUT} = 1\mu F$, unless otherwise noted. Typical values are at $T_A = +25^{\circ}C$.)

Parameter	Symbol	Conditions	Min	Typ	Max	Unit
Input Voltage RANGE	V_{IN}		2.2		6	V
NMOS OUTPUT On-Resistance	$R_{DS(ON)}$	$I_L = 500mA$		150	200	m Ω
Quiescent Current	I_Q	$V_{IN} = 3V$		19	40	μA
		$V_{IN} = 5V$		23	45	
Turn-On Time	T_R	$R_L = 10\Omega$, 90% Settling		400		μs
Current Limit Setting	I_{LIMIT}	HM9701AB $R_L = 2\Omega$	0.9	1	1.1	A
		HM9701BB $R_L = 2\Omega$	0.6	0.65	0.7	A
EN PIN Input High Voltage			1.5			V
EN PIN Input Low Voltage					0.8	V
Shutdown current	I_{OFF}	EN = "0"		0.1	1	μA
Output leakage current	$I_{LEAKAGE}$	EN = "0" $V_{OUT} = 0V$		0.5	10	μA
V_{IN} Under voltage LOCKOUT	U_{VLO}		1.3	1.8		V
V_{IN} under voltage Hysteresis				100		mV
Thermal Limit	T_{SD}			130		$^{\circ}C$
Thermal Limit Hysteresis	ΔT_{SD}			20		$^{\circ}C$

■ Package Information

- SOT-23-5

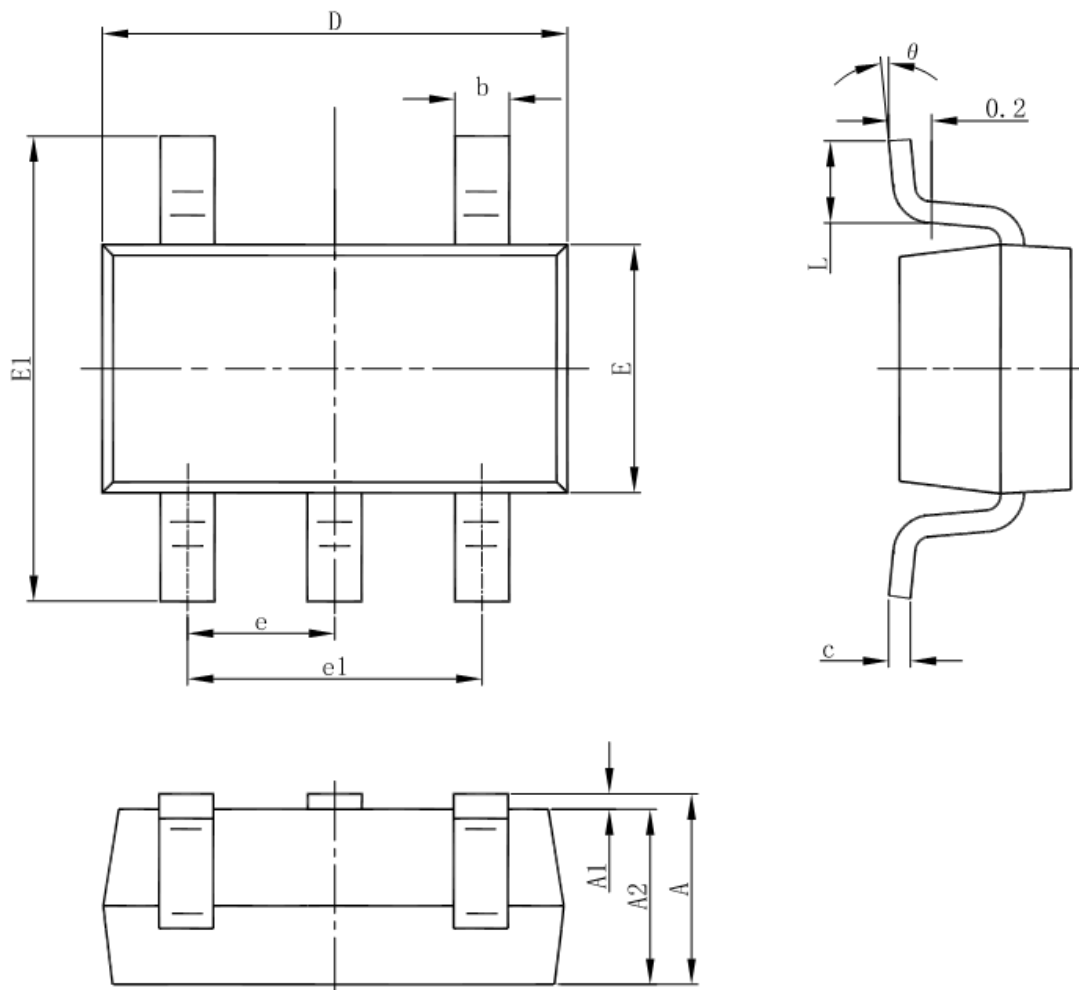

Symbol	Dimensions In Millimeters		Dimensions In Inches	
	Min	Max	Min	Max
A	1.050	1.250	0.041	0.049
A1	0.000	0.100	0.000	0.004
A2	1.050	1.150	0.041	0.045
b	0.300	0.500	0.012	0.020
c	0.100	0.200	0.004	0.008
D	2.820	3.020	0.111	0.119
E	1.500	1.700	0.059	0.067
E1	2.650	2.950	0.104	0.116
e	0.950(BSC)		0.037(BSC)	
e1	1.800	2.000	0.071	0.079
L	0.300	0.600	0.012	0.024
θ	0°	8°	0°	8°