

## 10W CAR RADIO AUDIO AMPLIFIER

### DESCRIPTION

The TDA2003A has improved performance with the same pin configuration as the TDA2002. The additional features of TDA2002, very low number of external components, ease of assembly, space and cost saving, are maintained.

The device provides a high output current capacity (up to 3.5A) very low harmonic and crossover distortion. Completely safe operation is guaranteed due to protection against DC and AC short circuit between all pins and ground.

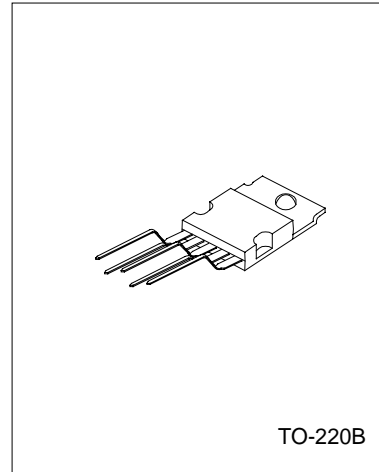

TO-220B

### ABSOLUTE MAXIMUM RATINGS ( $T_a=25^\circ\text{C}$ )

CHARACTERISTICS	SYMBOL	VALUE	UNITS
DC supply Voltage	$V_s$	28	V
Operating supply voltage	$V_s$	18	V
Power dissipation at $T_{case}=90^\circ\text{C}$	$P_{tot}$	20	W
Storage temperature	$T_{stg}$	-40~+150	$^\circ\text{C}$
junction temperature	$T_j$	-40~+150	$^\circ\text{C}$

### PIN CONNECTION

- 1 Non inverting input
- 2 Inverting input
- 3 Ground
- 4 Output
- 5 Supply Voltage

# TDA2003A

# LINEAR INTEGRATED CIRCUIT

## SCHEMATIC DIAGRAM

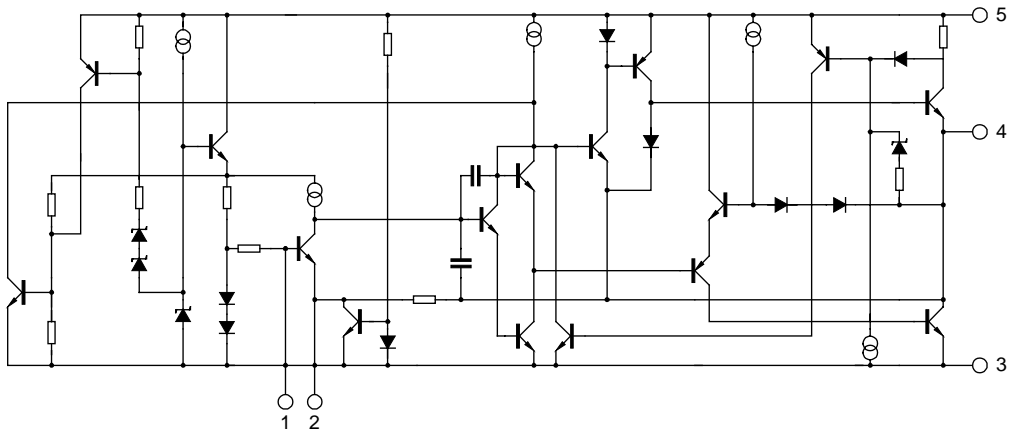

## TEST CIRCUIT

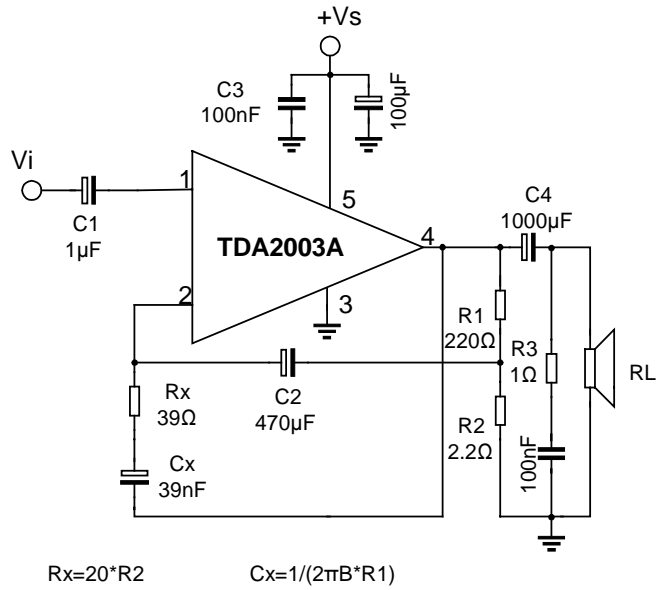

# TDA2003A

# LINEAR INTEGRATED CIRCUIT

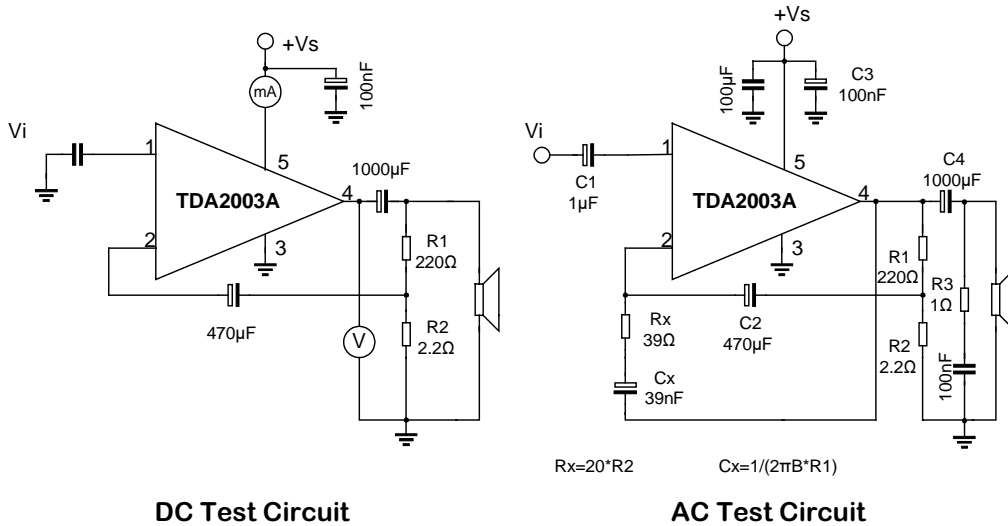

**DC Test Circuit**

**AC Test Circuit**

**ELECTRICAL CHARACTERISTICS**(Refer to the test circuit,  $V_s = 15V, T_a = 25^\circ C$ )

PARAMETER	SYMBOL	TEST CONDITIONS	MIN	TYP	MAX	UNIT
<b>DC CHARACTERISTICS</b>						
Supply Voltage	$V_s$		8		18	V
Quiescent Output Voltage	$V_o$		6.1	6.9	7.7	V
Quiescent drain current	$I_d$			44	50	mA
<b>AC CHARACTERISTICS</b>						
Output power	$P_o$	$d=10\%, f=1kHz$				W
		$R_L=8\Omega$	5.5	6		
		$R_L=2\Omega$	9	10		
		$R_L=3.2\Omega$		7.5		
Input sensitivity	$V_i$	$f=1kHz$				mV
		$P_o=0.5W, R_L=4\Omega$		14		
		$P_o=6W, R_L=4\Omega$		55		
		$P_o=0.5W, R_L=2\Omega$		10		
Input saturation voltage	$V_i(rms)$			300		mV
Frequency response(-3dB)	B	$P_o=1W, R_L=4\Omega$	40		15000	Hz
Distortion	D	$f=1kHz$				%
		$P_o=0.05$ to $4.5W, R_L=4\Omega$		0.15		
		$P_o=0.05$ to $7.5W, R_L=2\Omega$		0.15		

(continued)

PARAMETER	SYMBOL	TEST CONDITIONS	MIN	TYP	MAX	UNIT
Input Resistance (pin 1)	R <sub>i</sub>	open loop, f=1kHz	70	150		kΩ
Input noise current	e <sub>N</sub>			60	200	pA
Input noise voltage	I <sub>N</sub>			1	5	μV
open loop voltage gain	G <sub>vo</sub>	f=1kHz		80		dB
		f=10kHz		60		dB
closed loop voltage gain	G <sub>vc</sub>	f=1kHz, R <sub>L</sub> =4Ω	39.3	40	40.3	dB
Efficiency	η	f=1kHz P <sub>o</sub> =6W, R <sub>L</sub> =4Ω		69		%
		P <sub>o</sub> =10W, R <sub>L</sub> =2Ω		65		%
Supply voltage rejection	SVR	f=100Hz, V <sub>ripple</sub> =0.5V R <sub>g</sub> =10kΩ, R <sub>L</sub> =4Ω	30	36		dB

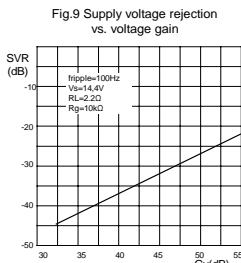
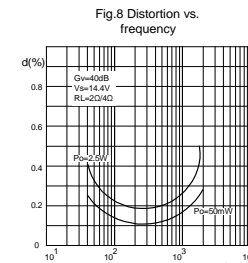
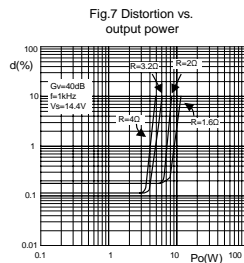
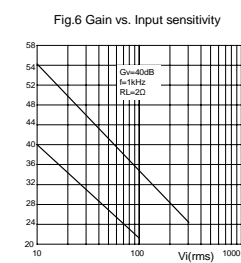
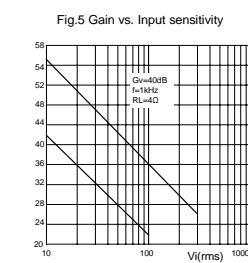
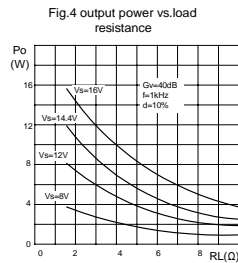
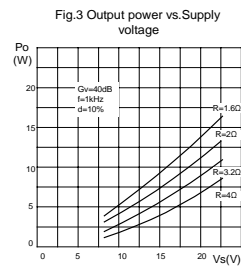
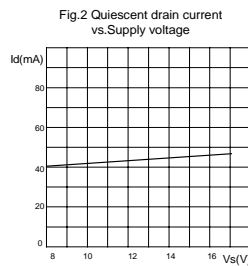
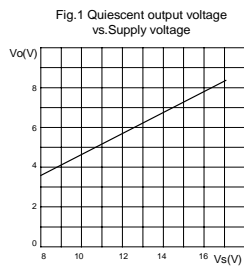

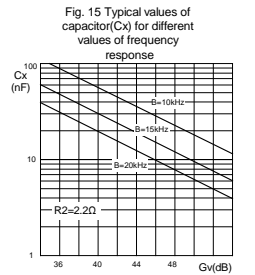
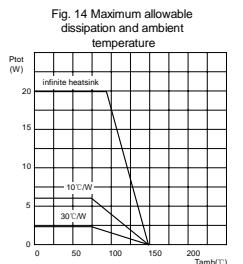
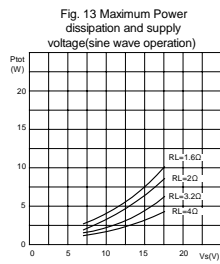
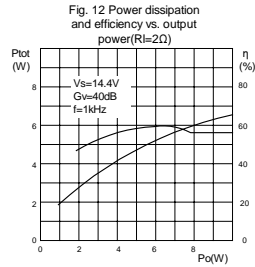
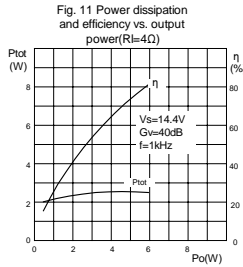
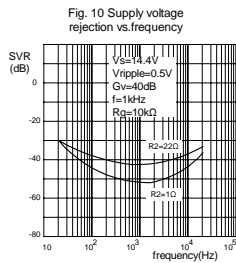

APPLICATION INFORMATION

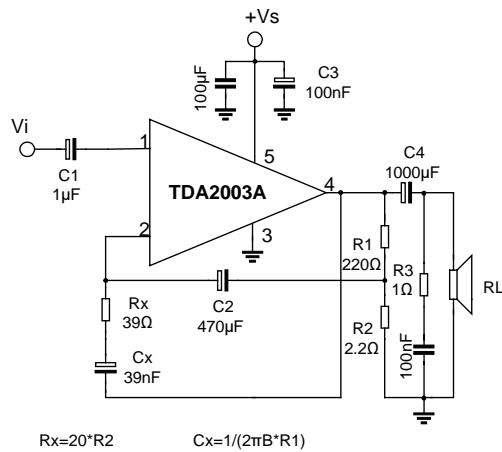

Fig 16 Typical application circuit

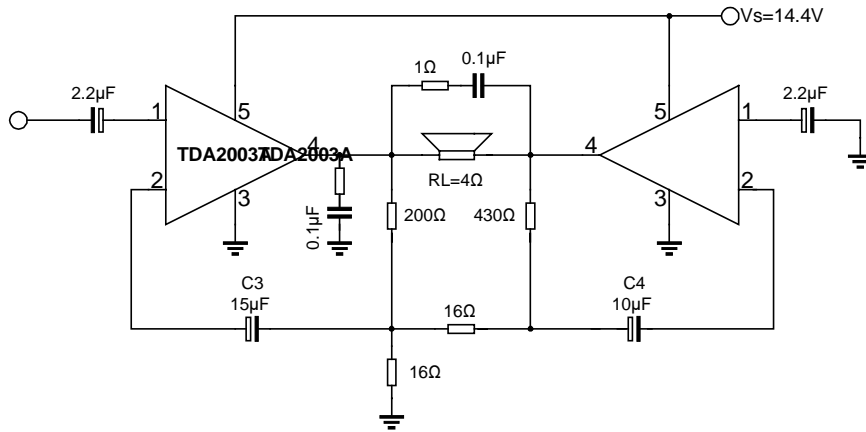

Fig.18 20W Bridge configuration application

The Values of the capacitors C3 and C4 are different to optimize the SVR(Typ. 40dB)

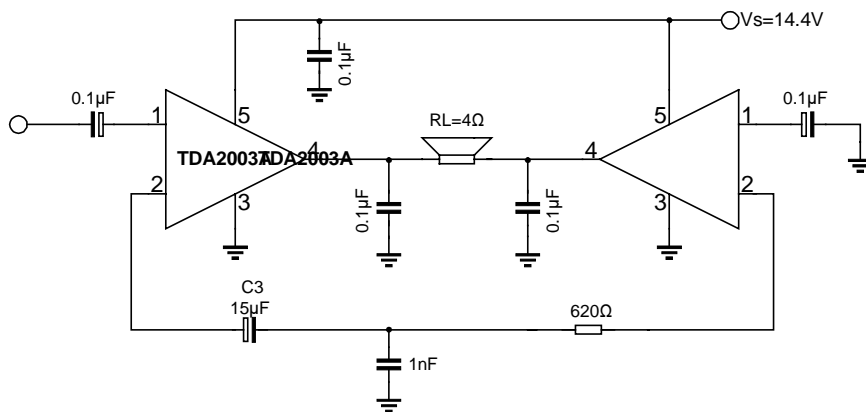

Fig.20 Low cost bridge configuration application circuit( $P_o=18W$ )

**BUILT-IN PROTECTION SYSTEMS**

**Load dump voltage surge**

The TDA2003A has a circuit which enables it to withstand a voltage pulse train, on pin 5, of the type shown in Fig.23.

**APPLICATION SUGGESTION**

The recommended values of the components are those shown on application circuit of Fig.16. Different values can be used. The following table can help the designer.

Component	Recommended value	Purpose	Large than recommended value	Large than recommended value
R1	$(Gv-1)*R2$	gain setting.		increase of Gain
R2	$2.2\Omega$	gain and SVR setting.	Decrease of SVR	
R3	$1\Omega$	Frequency stability	Danger of oscillation at high frequencies with inductive loads.	
Rx	$\approx 20*R2$	Upper frequency cutoff	Poor high frequencies attenuation	Dange of oscillation
C1	$2.2\mu F$	Input DC decoupling		Noise at switch-on switch-off
C2	$470\mu F$	Ripple rejection		Decrease of SVR
C3	$0.1\mu F$	Supply voltage bypass		Dange of oscillation
C4	$100\mu F$	Supply voltage bypass		Higher low frequency cutoff
C5	$0.1\mu F$	Frequency stability		Danger of oscillation at high frequencies with inductive loads.
Cx	$\approx / (2 \pi * B * R1)$	Upper frequency cutoff	smaller bandwidth	Larger bandwidth