

One Cell Lithium-ion/Polymer Battery Protection IC

■ **DESCRIPTION**

The UP6555A series product is a high integration solution for lithium-ion/polymer battery protection. UP6555A contains advanced power MOSFET, high-accuracy voltage detection circuits and delay circuits. UP6555A is put into a small package and only one external component makes it an ideal solution in limited space of battery pack. UP6555A has all the protection functions required in the battery application including overcharging, over-discharging, overcurrent and load short circuiting protection etc. The accurate safe and full utilization charging. The low standby current drains little current from the cell while in storage. The device is only targeted for digital cellular phones, but also for any other Li-ion and Li-Poly battery-powered information appliance requiring long-term battery life.

■ **FEATURE**

- ◆ Protection of Charger Reverse Connection
- ◆ Protection of Battery Cell Reverse Connection
- ◆ Integrate MOSFET
- ◆ Over-temperature Protection
- ◆ Two-step Overcurrent Detection:
 - Over-discharge Current
 - Load Short Circuiting
- ◆ Charger Detection Function
- ◆ 0V Battery Charging Function
- ◆ High-accuracy Voltage Detection
- ◆ Low Current Consumption
- ◆ Operation Mode: 3uA typ
- ◆ Power-down Mode: 1.0uA typ

■ **APPLICATIONS**

- ◆ One-Cell Lithium-ion Battery Pack
- ◆ Lithium-Polymer Battery Pack

■ **PIN CONFIGURATION**

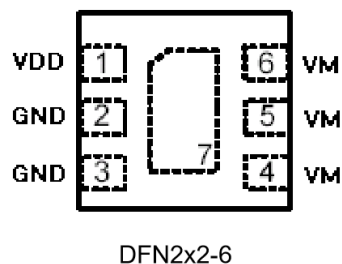
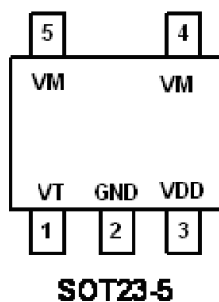
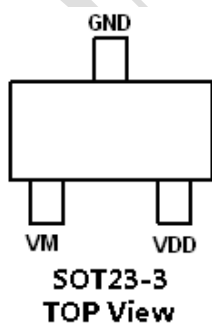

■ **PART NUMBER INFORMATION**

UP6555AX	X=Package Code P: SOT23 S: SOT23-5L D: DFN2X2-6L
----------	---

■ **ORDERING INFORMATION**

Part Number	Overcharge Detection Voltage	Overcharge Release Voltage	Overdischarge Detection Voltage	Overdischarge Release Voltage	OverCurrent Detection Current
UP6555AS	4.3	4.1	2.4	3.0	2.8
UP6555AP	4.3	4.1	2.4	3.0	2.8
UP6555AD	4.3	4.1	2.4	3.0	2.8

■ **ABSOLUTE MAXIMUM RATINGS** ($T_A = 25^\circ\text{C}$ Unless otherwise noted)

Symbol	Parameter	Typical	Unit
V _{DD}	Supply Voltage	-0.3~6	V
V _M	Input Pin Voltage	-6~8	V
T _J	Operation Junction Temperature	150	°C
T _{STG}	Storage Temperature Range	-55~+125	°C
T _{OPR}	Operation Temperature	-40~+80	°C

Note: Absolute maximum ratings are those values beyond which the device could be permanently damaged. Absolute maximum ratings are stress rating only and functional device operation is not implied

■ **THERMAL DATA**

Symbol	Parameter	Package	Max	Unit
R _{θJA}	Thermal Resistance-Junction to Ambient	SOT23	500	°C/W
		SOT23-5L	200	°C/W
		DFN2X2-6L	200	°C/W
P _D	Power Dissipation	SOT23	0.2	W
		SOT23-5L	0.3	W
		DFN2X2-6L	0.5	W

■ **ELECTRICAL CHARACTERISTICS** ($T_A=25\text{ }^\circ\text{C}$ Unless otherwise noted)

Symbol	Parameter	Condition	Min	Typ	Max	Unit
Detection Voltage						
V_{CU}	Overcharge Detection Voltage		$V_{CU}-0.05$	V_{CU}	$V_{CU}+0.05$	V
V_{CL}	Overcharge Release Voltage		$V_{CL}-0.05$	V_{CL}	$V_{CL}+0.05$	V
V_{DL}	Overdischarge Detection Voltage		$V_{DL}-0.1$	V_{DL}	$V_{DL}+0.1$	V
V_{DR}	Overdischarge Release Voltage		$V_{DR}-0.1$	V_{DR}	$V_{DR}+0.1$	V
V_{CHA}	Charger Detection Voltage			-0.12		V
Detection Current						
I_{IOV}	Overdischarge Current Detection	$V_{DD}=3.5V$	2.4	2.8	3.2	A
I_{SHORT}	Load Short-Circuiting Detection	$V_{DD}=3.5V$	8	12	16	A
Current Consumption						
I_{OPE}	Current Consumption in Normal Operation	$V_{DD}=3.5V$ $V_M=0V$		3	6	μA
I_{PDN}	Current Consumption in Power Down	$V_{DD}=2.0V$ V_M pin floating		1	3	μA
VM Internal Resistance						
* R_{VMD}	Internal Resistance Between VM and VDD	$V_{DD}=3.5V$ $V_M=1.0V$		320		$k\Omega$
* R_{VMS}	Internal Resistance Between VM and GND	$V_{DD}=2.0V$ $V_M=1.0V$		100		$k\Omega$
FET on Resistance						
* $R_{SS(ON)}$	Equivalent FET on Resistance	$V_{DD}=3.6V$ $I_{VM}=1.0A$	45	55	65	$m\Omega$
Over Temperature Protection						
* T_{SHD+}	Over Temperature Protection			120		$^\circ C$
* T_{SHD-}	Over Temperature Recovery Degree			100		$^\circ C$
Detection Delay Time						
t_{CU}	Overcharge Voltage Detection Delay Time			150	200	mS
t_{DL}	Overdischarge Voltage Detection Delay Time			80	100	mS
* t_{IOV}	Overdischarge Current Detection Delay Time			10	20	mS
* t_{SHORT}	Load Short-Circuiting Detection Delay Time			150	200	μS

Note: * The parameter is guaranteed by design

■ FUNCTIONAL DESCRIPTION

The UP6555A the voltage and current of a battery and protects it from being damaged due to overcharge voltage, overdischarge voltage, overdischarge current, and short circuit conditions by disconnecting the battery from the load or charger. These functions are required in order to operate the battery cell within specified limits. The device requires only one external capacitor. The MOSFET is integrated and its $R_{SS(ON)}$ is as low as 60m Ω typical

Normal operating mode

If no exception condition is detected, charging and discharging can be carried out freely. This condition is called the normal operating mode.

Overcharge Condition

When the battery voltage becomes higher than the overcharge detection voltage (V_{CU}) during charging under normal condition and the state continues for the overcharge detection delay time (t_{CU}) or longer, the UP6555A turns the charging control FET off to stop charging. This condition is called the overcharge condition. The overcharge condition is released in the following two cases:

1. When the battery voltage drops below the overcharge release voltage (V_{CL}), the UP6555A turns the charging control FET on and returns to the normal condition.
2. When a load is connected and discharging starts, the UP6555A turns the charging control FET on and returns to the normal condition. The release mechanism is as follows: the discharging current flows through an internal parasitic diode of the charging FET immediately after a load is connected and discharging starts, and the VM pin voltage increases about 0.7V(forward voltage of the diode) from the GND pin voltage momentarily the UP6555A detects this voltage and releases the overcharge condition. Consequently, in the case that the battery voltage is equal to or lower than the overcharge detection voltage (V_{CU}), the UP6555A returns to the normal condition immediately, but in the case the battery voltage is higher than the overcharge detection voltage (V_{CU}), the chip does not return to the normal condition until the battery voltage drops below the overcharge detection voltage (V_{CU}) even if the load is connected. In addition. If the VM pin voltage is equal to or lower than the overcurrent 1 detection voltage when a load is connected and discharging starts, load is connected and discharging starts, the chip does not return to the normal condition

Remark If the battery is charged to a voltage higher than the overcharge detection voltage (V_{CU}) and the battery voltage does not drop below the overcharge detection voltage (V_{CU}) even when a heavy load, which causes an overcurrent, is connected, the overcurrent 1 and overcurrent 2 do not work until the battery voltage drops below the overcharge detection voltage (V_{CU}). Since an actual battery has, however, an internal impedance of several dozens of m Ω , and the battery voltage drops immediately after a heavy load which causes an overcurrent is connected, the overcurrent 1 and overcurrent 2 work. Detection of load short-circuiting works regardless of the battery voltage.

Overdischarge Condition

When the battery voltage drops below the overdischarge detection voltage (V_{DL}) during discharging under normal condition and it continues for the overdischarge detection delay time (t_{DL}) or longer, the UP6555A turns the discharging condition. After the discharging control FET is turned off, the VM pin is pulled up by the R_{VMD} resistor between VM and VDD in UP6555A. meanwhile when VM is bigger than 1.5V (typ.) (the load short-circuiting detection voltage), the current of the chip reduced to the power-down current (I_{PDN}). This condition is called power-down condition. The VM and VDD pins are shorted by the R_{VMD} resistor in the IC

under the overdischarge and power-down conditions. The power-down condition is released when a charger is connected and the potential difference between VM and VDD becomes 1.3V (typ.) or higher (load short-circuiting detection voltage). At this time, the FET is still off. When the battery voltage becomes the overdischarge detection voltage (V_{DL}) or higher (see note), the UP6555A turns the FET on and changes to the normal condition from the overdischarge condition.

Remark If the VM pin voltage is no less than the charger detection voltage (V_{CHA}), the battery under overdischarge condition is connected to a charger, the overdischarge condition is released (the discharging control FET is turned on) as usual, provided that the battery voltage reaches the overdischarge release voltage (V_{DU}) or higher.

Overcurrent Condition

When the discharging current becomes equal to or higher than a specified value (the VM pin voltage is equal to or higher than the overcurrent detection voltage) during discharging under normal condition and the state continues for the overcurrent detection delay time or longer, the UP6555A turns off the discharging control FET to stop discharging. This condition is called overcurrent condition. (The overcurrent includes overcurrent or load short-circuiting). The VM and GND pins are shorted internally by the R_{VMS} resistor under the overcurrent condition. When a load is connected, the VM pin voltage equals the VDD voltage due to the load. The overcurrent condition returns to the normal condition when the load is released and the impedance between the B+ and B- pins becomes higher than the automatic recoverable impedance. When the load is removed, the VM pin goes back to the GND potential since the VM pin potential is lower than the overcurrent detection voltage (V_{IOV1}), the IC returns to the normal condition.

Abnormal Charge Current Detection

If the VM pin voltage drops below the charger detection voltage (V_{CHA}) during charging under the normal condition and it continues for the overcharge detection delay time (t_{CU}) or longer, the UP6555A turns the charging control FET off and stops charging. This action is called abnormal charge current detection. Abnormal charge current detection works when the discharging control FET is on and the VM pin voltage droops below the charger detection voltage (V_{CHA}). When an abnormal charge current flows into a battery in the overdischarge condition, the UP6555A consequently turns the charging control FET off and stops charging after the battery voltage becomes the overdischarge detection voltage and the overcharge detection delay time (t_{CU}) elapses. Abnormal charge current detection is released when the voltage difference between VM pin and GND pin becomes lower than the charger detection voltage (V_{CHA}) by separating the charger. Since the 0V battery charging function has higher priority than the abnormal charge current detection function, abnormal charge current may not be detected by the product with the 0V battery charging function while the battery voltage is low.

Load Short-circuiting Condition

If voltage of VM pin is equal or below short-circuiting protection voltage (V_{SHORT}), the UP6555A will stop discharging and battery is disconnected from load. The maximum delay time to switch current off is t_{SHORT} . This status is released when voltage of VM pin is higher than short protection voltage (V_{SHORT}), such as when disconnecting the load.

Delay Circuits

The detection delay time for overdischarge current 2 and load short-circuiting starts when overdischarge current 1 is detected. As soon as overdischarge current 2 or load short-circuiting is detected over detection

delay time for overdischarge current 2 or load short-circuiting, the UP6555A stops discharging. When battery voltage falls below overdischarge detection voltage due to overdischarge current, the UP6555A stop discharging by overdischarge current detection. In this case the recovery of battery voltage is so slow that if battery voltage after overdischarge voltage detection delay time is still lower than overdischarge detection voltage, the UP6555A shifts to power-down.

0V Battery Charging Function^{1 2 3}

This function enables the charging of a connected battery whose voltage is 0V by self-discharge. When a charger having 0V battery start charging charger voltage (V_{0CHA}) or higher is connected between B+ and B- pins, the charging control FET gate is fixed to VDD potential. When the voltage between the gate and the source of the charging control FET becomes equal to or higher than the turn-on voltage by the charger voltage, the charging control FET is turned on to start charging. At this time, the discharging control FET is off and the charging current flows through the internal parasitic diode in the discharging control FET. If the battery voltage becomes equal to or higher than the overdischarge release voltage (V_{DU}), the normal condition returns.

■ **TYPICAL APPLICATION**

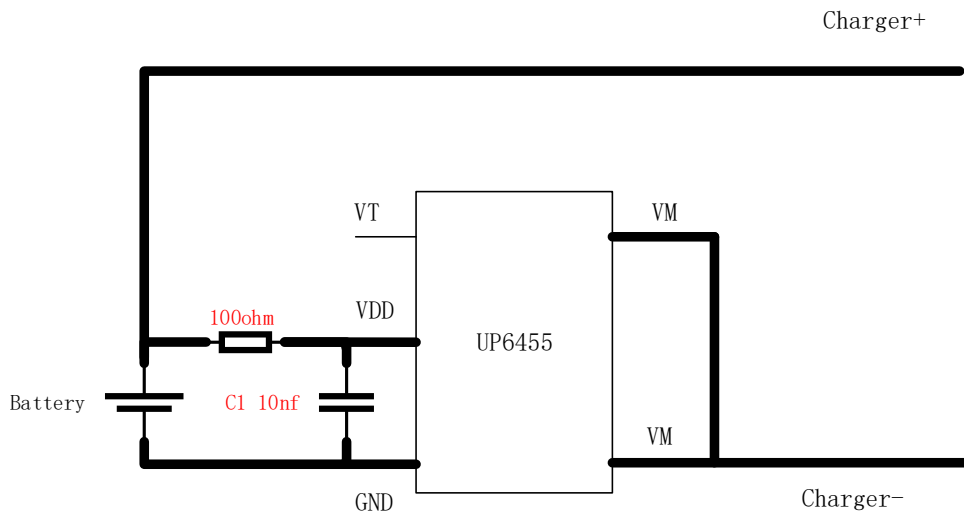

■ **TIMING CHART**

Overcharge and overdischarge detection

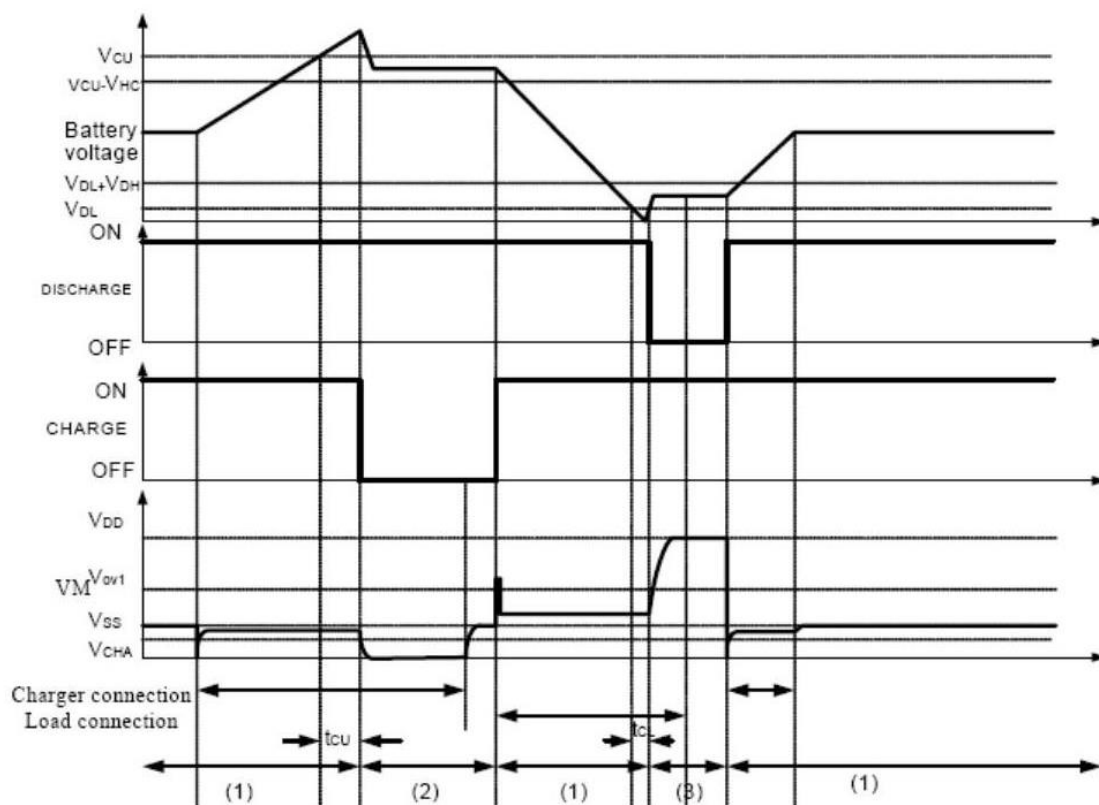

Overdischarge current detection

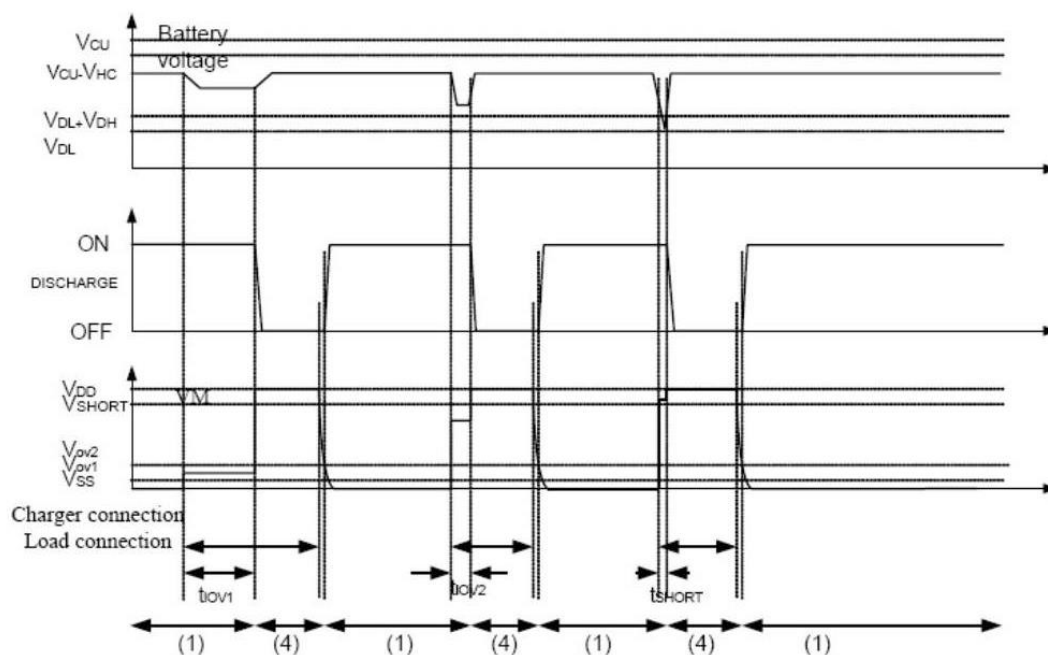

Charger Detection

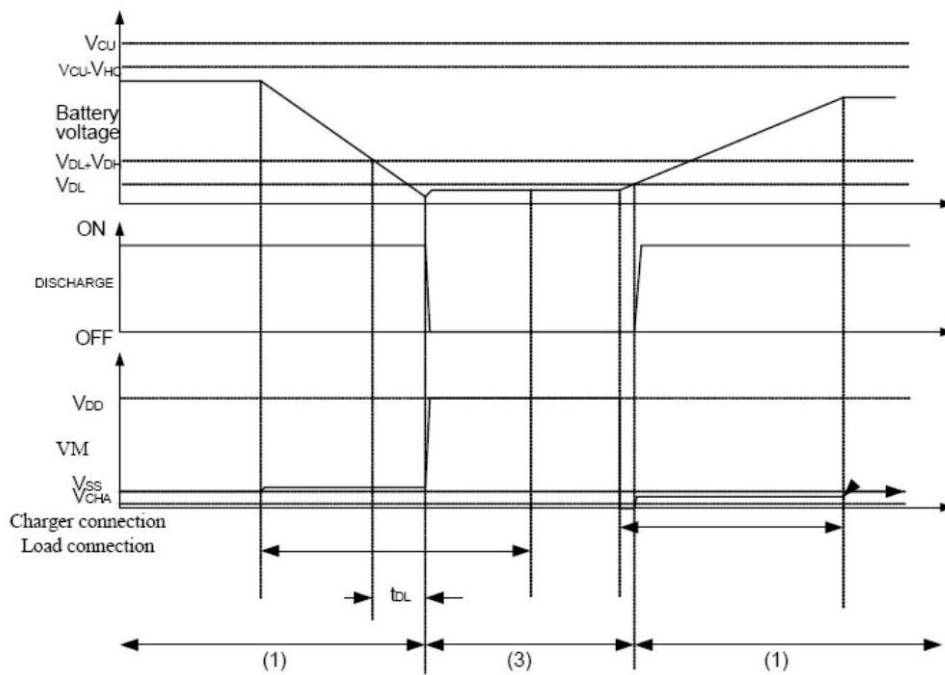

Abnormal Charger Detection

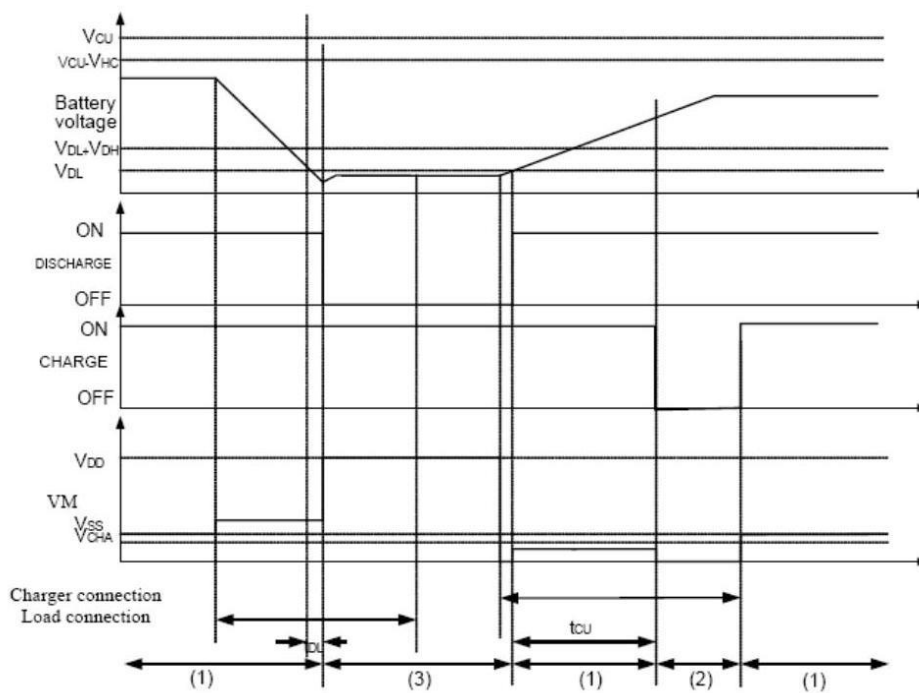

■ **PACKAGE DIENSIONS**

SOT-23 PACKAGE OUTLINE DIMENSIONS

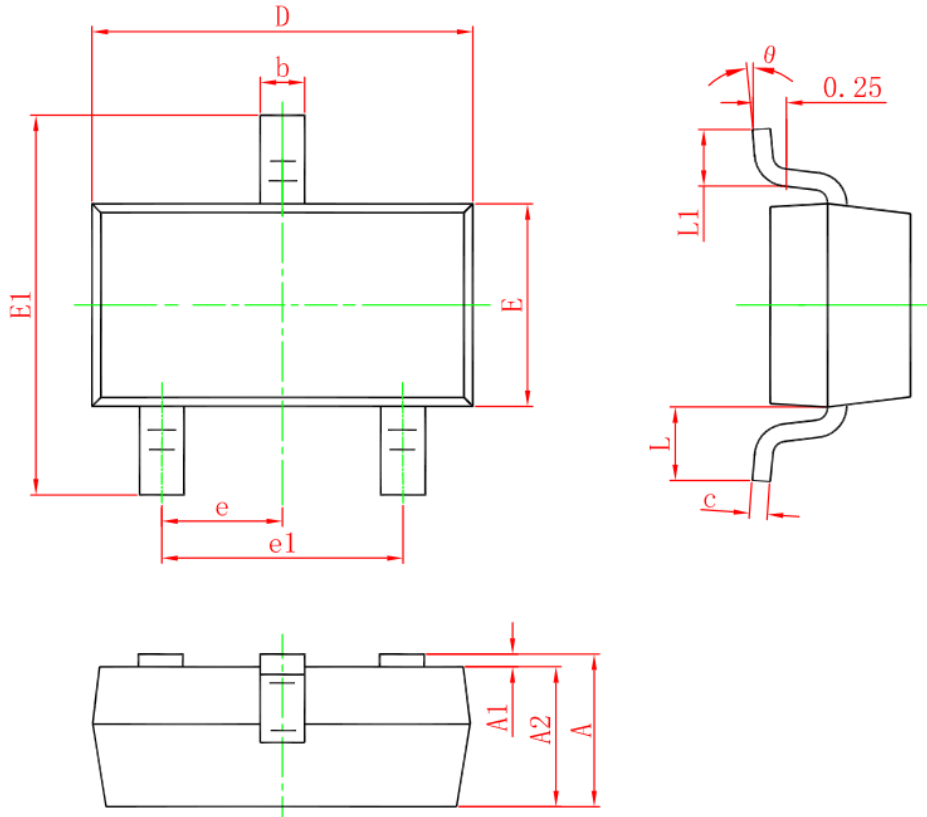

Symbol	Dimensions In Millimeters		Dimensions In Inches	
	Min.	Max.	Min.	Max.
A	0.900	1.150	0.035	0.045
A1	0.000	0.100	0.000	0.004
A2	0.900	1.050	0.035	0.041
b	0.300	0.500	0.012	0.020
c	0.080	0.150	0.003	0.006
D	2.800	3.000	0.110	0.118
E	1.200	1.400	0.047	0.055
E1	2.250	2.550	0.089	0.100
e	0.950 TYP.		0.037 TYP.	
e1	1.800	2.000	0.071	0.079
L	0.550 REF.		0.022 REF.	
L1	0.300	0.500	0.012	0.020
θ	0°	8°	0°	8°

TSOT-23-5L PACKAGE OUTLINE DIMENSIONS

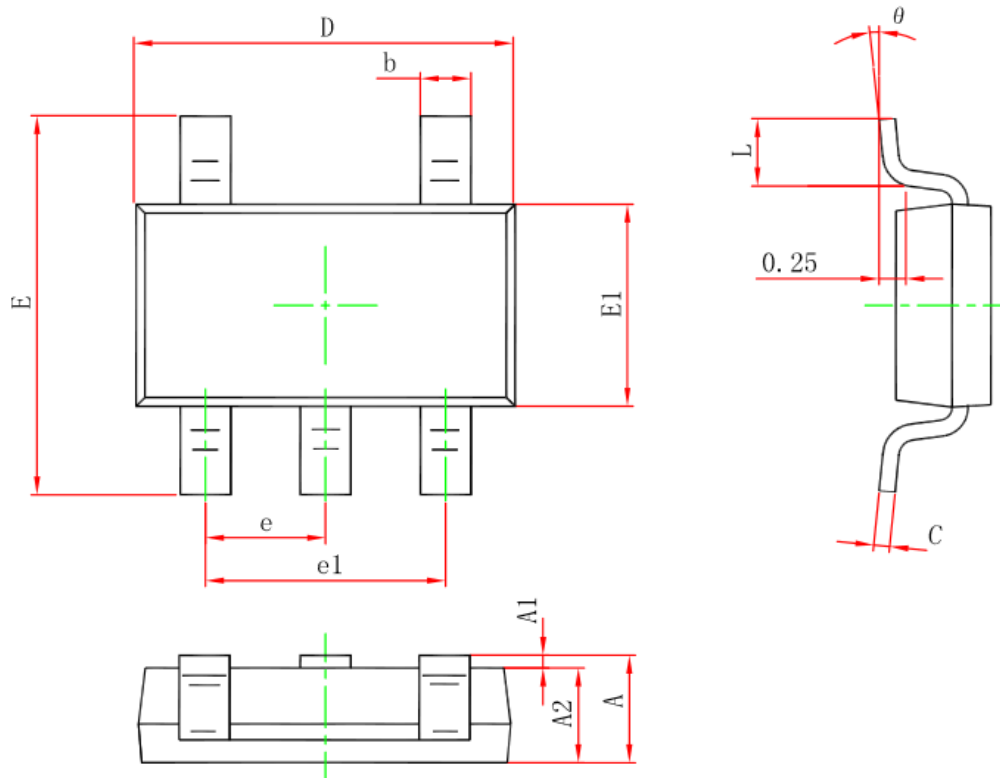

Symbol	Dimensions In Millimeters		Dimensions In Inches	
	Min	Max	Min	Max
A	---	0.900	---	0.035
A1	0.020	0.090	0.001	0.004
A2	0.700	0.800	0.028	0.031
b	0.350	0.500	0.014	0.020
c	0.080	0.200	0.003	0.008
D	2.820	3.020	0.111	0.119
E1	1.600	1.700	0.063	0.067
E	2.650	2.950	0.104	0.116
e	0.95 (BSC)		0.037(BSC)	
e1	1.90 (BSC)		0.075(BSC)	
L	0.300	0.600	0.012	0.024
theta	0°	8°	0°	8°

DFNWB2×2-6L-F(P0.65T0.50/0.55/0.60) PACKAGE OUTLINE DIMENSIONS

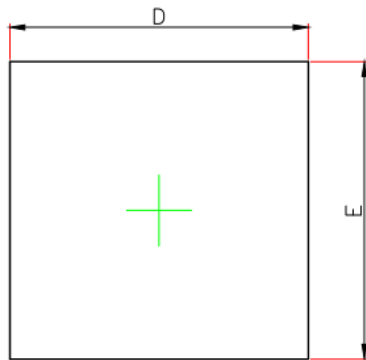

TOP VIEW

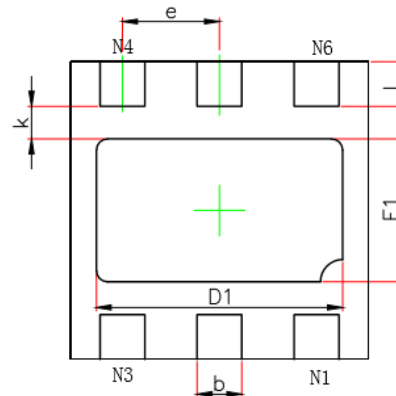

BOTTOM VIEW

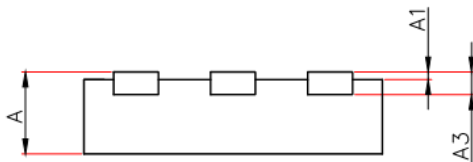

SIDE VIEW

Symbol	Dimensions In Millimeters		Dimensions In Inches	
	Min.	Max.	Min.	Max.
A	0.450/0.500/0.550	0.550/0.600/0.650	0.018/0.020/0.022	0.022/0.024/0.026
A1	0.000	0.050	0.000	0.002
A3	0.700	0.800		
A3	0.152REF.		0.006REF.	
D	1.924	2.076	0.076	0.082
E	1.924	2.076	0.075	0.083
D1	1.550	1.750	0.061	0.069
E1	0.860	1.060	0.034	0.042
k	0.200MIN.		0.008MIN.	
b	0.250	0.350	0.007	0.012
e	0.650TYP.		0.026TYP.	
L	0.224	0.376	0.009	0.015

■ **SOLDERING METHODS FOR UNIVERCHIP**

Storage environment Temperature=10°C~35°C Humidity=65%±15%

Reflow soldering of surface mount device

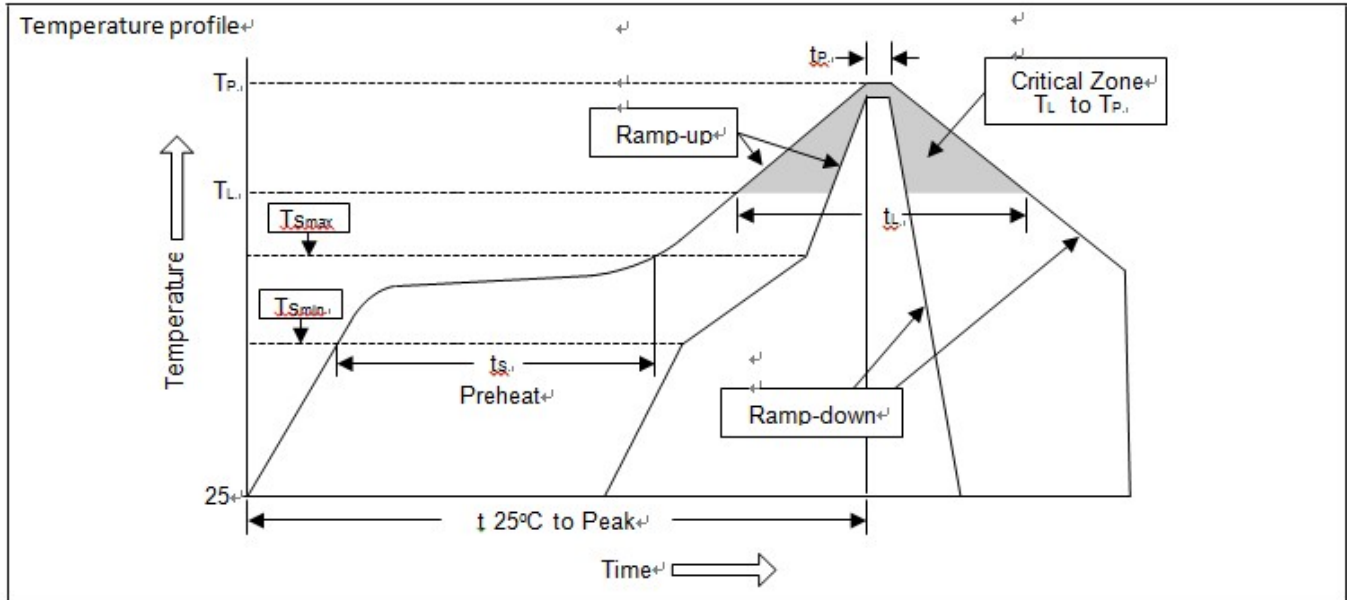

Profile Feature	Sn-Pb Eutectic Assembly	Pb free Assembly
Average ramp-up rate (T_L to T_P)	<3°C/sec	<3°C/sec
Preheat		
-Temperature Min (T_{Smin})	100°C	150°C
-Temperature Max (T_{Smax})	150°C	200°C
-Time (min to max) (t_s)	60~120 sec	60~180 sec
T_{Smax} to T_L		
-Ramp-up Rate	<3°C/sec	<3°C/sec
Time maintained above		
-Temperature (T_L)	183°C	217°C
-Time (t_L)	60~150 sec	60~150 sec
Peak Temperature (T_P)	240°C+0/-5°C	260°C+0/-5°C
Time within 5°C of actual Peak Temperature (t_p)	10~30 sec	20~40 sec
Ramp-down Rate	<6°C/sec	<6°C/sec
Time 25°C to Peak Temperature	<6 minutes	<6 minutes