

HM5806G-SOC of Li-Battery Transfer to Dry Battery Solution

GENERAL DESCRIPTION

HM5806G is one SOC that it integrates one High precision current battery charger and Buck converter in only DFN3x3-10 package.

This SOC can output 1.5Vout 2A with Li-Battery Input and also can charge with 700mA current.

It only need few components and can reduce the BOM area and BOM cost.

FEATURES

- 2.5V to 5.5V Input Range
- 2A Output Capability
- High Efficiency up to 95%
- Low Quiescent Current 20uA
- Adjustable Output Voltage from 0.6V to VIN

- 1.5MHz Constant Frequency Operation
- Under Voltage Lockout, Over Current, Short Current, and Thermal Protection
- 700mA charging Capability
- Constant-Current/Constant-Voltage Operation with Thermal Regulation to Maximize Charge Rate Without Risk of Overheating
- Preset 4.35V Charge Voltage with $\pm 1\%$ Accuracy
- Charge state pairs of output, no battery and fault status display
- C/10 Charge Termination
- 2.9V Trickle Charge Threshold
- Operating Temperature: -40°C to $+85^{\circ}\text{C}$
- Available in very tiny DFN3X3-10L Package
- RoHS Compliant and 100% Lead(Pb)-Free

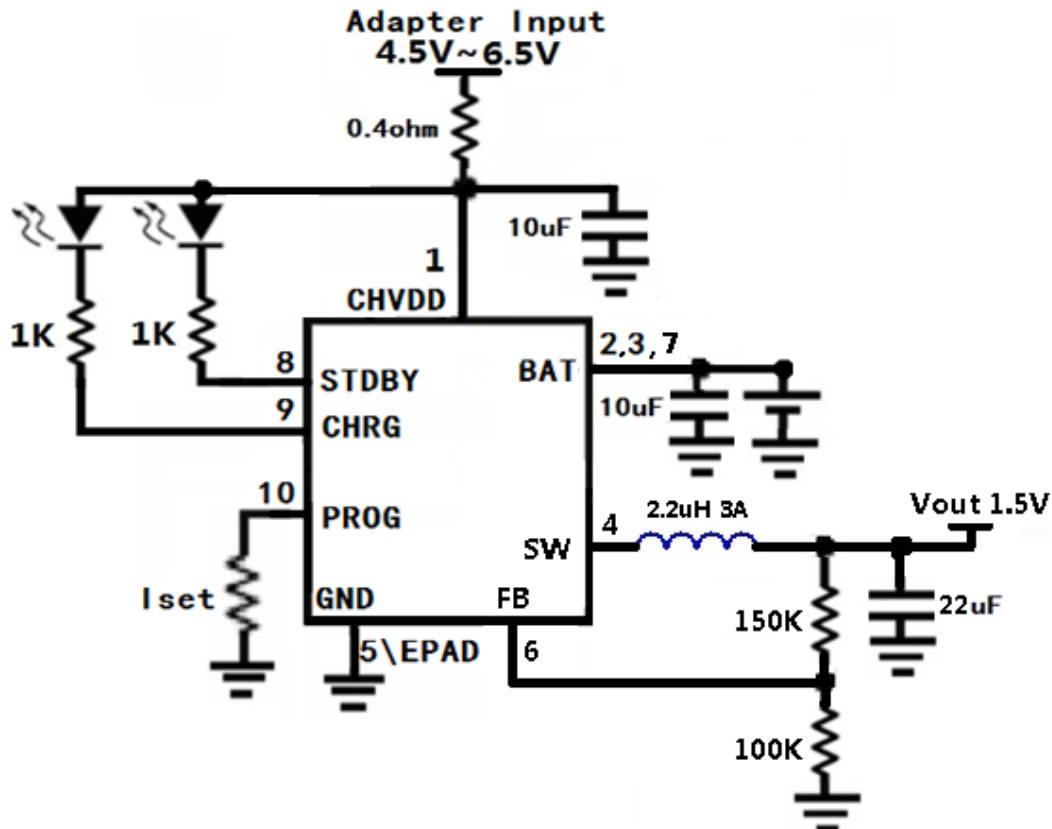

ORDERING INFORMATION

PART NUMBER	TEMP RANGE	VIN LI-BATTERY	OUTPUT VOLTAGE (V)	ISET (MAX)	VBAT	MARK	PACKAGE	PINS
HM5806G	-40°C to 85°C	2.5V~5.5V	ADJ	700mA	4.35V	HM5806GYW	DFN3x3	10

Note: "YW" is manufacture date code, "Y" means the year, "W" means the week

PIN CONFIGURATION

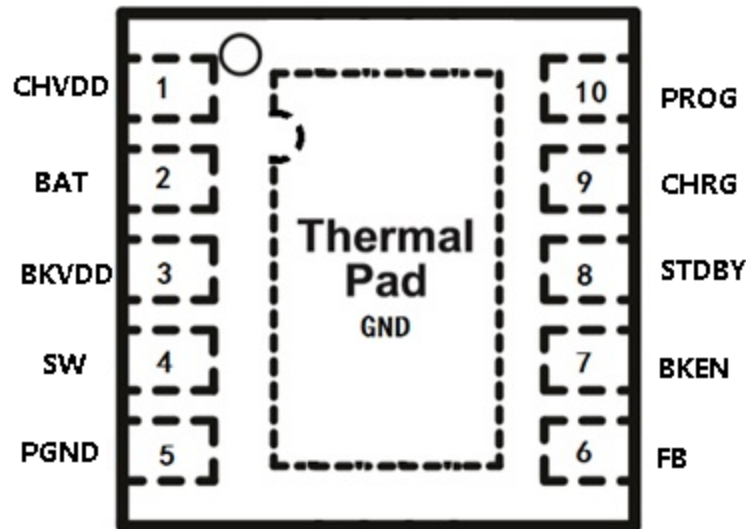

Figure 2. PIN Configuration

PIN DESCRIPTION

PIN NUMBER	PIN NAME	PIN DESCRIPTION
1	CHVDD	The Adapter input, Need a 10uF capacitor bypass.
2	BAT	Li-Battery's Positive Pole, Need a 10uF capacitor bypass.
3	BKVDD	Power Supply of Buck regulator, Normally connect with BAT+ and BKEN, Need a 10uF capacitor bypass.
4	SW	Buck regulator Switch Pin
6	FB	Feedback Input. FB senses the output voltage to regulator that voltage. Drive FB with a resistive voltage divider from the output voltage. The feedback threshold is 0.6V
7	BKEN	Buck regulator enable Input. EN is a digital input that turns the regulator on or off. Drive EN high to turn on the regulator, driver it low to turn it off.
8	/STDBY	The completion of battery charging instructions side.
9	/CHRG	Open-Drain Charge Status Output.
10	PROG	Charge Current Program, Charge Current Monitor and Shutdown Pin.
5,EPAD	GND	Ground\ EPAD , Please connect with mass metal

ABSOLUTE MAXIMUM RATINGS

(Note: Do not exceed these limits to prevent damage to the device. Exposure to absolute maximum rating conditions for long periods may affect device reliability.)

PARAMETER	VALUE	UNIT
Supply Voltage CHVDD	-0.3V to +7V	V
Other Pins	-0.3V~5.5V	V
Operating Ambient Temperature	-40 to 85	°C
Maximum Junction Temperature	125	°C
Storage Temperature	-55 to 150	°C
Lead Temperature (Soldering, 10 sec)	300	°C

ELECTRICAL CHARACTERISTICS

($V_{IN} = 3.6V$, $T_A = 25^\circ C$ unless otherwise specified)

PARAMETER	SYMBOL	TEST CONDITIONS	MIN	TYP	MAX	UNIT
Input Voltage Range	Vbat		2.5		5.5	V
UVLO Threshold	V _{UVLO}	V _{HYSTERESIS} = 100mV	2.35	2.45	2.5	V
Operating Supply Current	I _{SUPPLY}	V _{FB} = 0.5V or V _{OUT} = 90%, I _{Load} = 0		130	170	μA
Standby Supply Current		V _{FB} = 0.7V or V _{OUT} = 110%, I _{Load} = 0		20		
Shutdown Supply		V _{EN} = 0V, V _{bat} = 4.2V		0.1	1	
Regulated Feedback Voltage	V _{FB}	T _a = 25°C	0.588	0.6	0.612	V
		0 < T _a < 85°C	0.5865	0.6	0.6135	
		-40°C < T _a < 85°C	0.585	0.6	0.615	
Reference Voltage Line Regulation		V _{bat} = 2.7V to 5.5V		0.04	0.4	%
Regulated Output Voltage	V _{OUT}	V _{OUT} = 1.5V; I _{OUT} = 100mA	1.455	1.5	1.545	V
Output Voltage Load Regulation				0.5		%
Peak Inductor Current	I _{PEAK}	V _{bat} = 3V, V _{FB} = 0.5V or V _{OUT} = 90%, Duty Cycle < 35%		3		A
Oscillator Frequency	F _{OSC}	V _{FB} = 0.6V or V _{OUT} = 100%	1.2	1.5	1.8	MHz
		V _{FB} = 0 or V _{OUT} = 0		220		KHz

Rds(ON) of P-channel FET		$I_{SW} = 100\text{mA}$		0.15	0.3	Ohm
Rds(ON) of N-channel FET		$I_{SW} = 100\text{mA}$		0.11	0.2	Ohm
Enable Threshold		$V_{bat} = 2.5\text{V to } 5.5\text{V}$	0.3	1	1.5	V
Enable Leakage Current			-0.1		0.1	μA
SW Leakage Current		$V_{EN} = 0\text{V}, V_{SW} = 0\text{V or } 5\text{V}, V_{bat} = 4.2\text{V}$	-1		1	μA
Input Voltage Range	CHVCC		4.25		6.5	V
Input supply current	Icc	Charge mode, RPROG =10K		350	2000	μA
		Standby mode		150	500	μA
		Shutdown mode(RPROG not connected, $V_{cc} < V_{bat}$ or $V_{cc} < V_{uv}$)		50	100	μA
BAT pin Current Input supply current	Ibat Icc	$R_{PROG} = 2\text{k}, \text{Current mode}$	450	500	550	mA
		$R_{PROG} = 10\text{k}, \text{Current mode}$	93	100	107	mA
		Standby mode, $V_{bat} = 4.35\text{V}$	0	-2.5	-6	μA
		Shutdown mode		1	2.5	μA
		Sleep mode, $V_{cc} = 0\text{V}$		0.3	2.5	μA
		Charge mode, RPROG =10K		350	2000	μA
Regulated Charge Voltage	Vfloat	$0^\circ\text{C} \leq T_A \leq 85^\circ\text{C}, I_{charge} = 40\text{mA}$	4.308	4.35	4.392	V
PROG pin Voltage	Vprog	$R_{PROG} = 10\text{k}, \text{Current mode}$	0.93	1.0	1.07	V
Trickle charge current	Itrikl	$V_{bat} < V_{trikl}, R_{prog} = 2\text{k}$	20	50	70	mA
Trickle charge Threshold Voltage	Vtrikl	$R_{PROG} = 10\text{K}, V_{bat}$ Rising	2.8	2.9	3.0	V
Trickle voltage hysteresis voltage	Vtrhys	$R_{PROG} = 10\text{K}$	60	80	110	mV
Recharge Battery threshold Voltage	ΔV_{recg}	$V_{FLOAT} - V_{RECHRG}$		150	300	mV
CHRG pin Output low voltage	Vchrg	$I_{chrg} = 5\text{mA}$		0.35	0.6	V
STBY pin Output low voltage	Vstby	$I_{stby} = 5\text{mA}$		0.35	0.6	V

FUNCTIONAL DESCRIPTION

NORMAL OPERATION

HM5806G integrates one High precision current battery charger and Buck converter in only DFN3x3-10 package.

In Buck normal operation the high-side MOSFET turns on each cycle and remains on until the current comparator turns it off. At this point the low-side MOSFET turns on and remains on until either the end of the switching cycle or until the inductor current approaches zero. The error amplifier adjusts the current comparator's threshold as necessary in order to ensure that the output remains in regulation.

In Battery Charger operation, The charge current is programmed by connecting a 1% resistor, RPROG, to ground. When charging in constant-current mode, this pin serves to 1V. In all modes, the voltage on this pin can be used to measure the charge current using the following formula:

$$IBAT = (VPROG/RPROG) \times 1000.$$

The PROG pin can also be used to shut down the charger. Disconnecting the program resistor from ground allows a 3uA current to pull the PROG pin high. When it reaches the 1.21V shutdown threshold voltage, the charger enters shutdown mode, charging stops and the input supply current drops to 50uA. This pin is also clamped to approximately 2.4V. Driving this pin to voltages beyond the clamp voltage will draw currents as high as 1.5mA. Reconnecting RPROG to ground will return the charger to normal operation.

When the battery is charging, the CHRГ pin is pulled low by an internal N-channel MOSFET. When the charge cycle is completed, CHRГ pin will be in a high-impedance state; When the battery charge is complete, STDBY pulled low by internal switches, indicating the completion of charging. In addition, STDBY pin will be in a high-impedance state

APPLICATION INFORMATION

INDUCTOR SELECTION

In normal operation, the inductor maintains continuous current to the output. The inductor current has a ripple that is dependent on the inductance value. The high inductance reduces the ripple current. In general, select the inductance by the following equation:

$$L = \frac{V_{OUT} \times (V_{IN} - V_{OUT})}{V_{IN} \cdot f \cdot \Delta I}$$

Where V_{OUT} is the output voltage, V_{IN} is the input voltage, f is the switch frequency, and ΔI is the peak-to-peak inductor ripple current. Typically, choose ΔI as the 30% of the maximum output current.

Manufacturer	Part Number	Inductance (uH)	DRC max (Ohms)	Dimensions L*W*H (mm3)
Murata	LQH5BPN	1	0.019	5*5*2
		2.2	0.030	
	LQH44PN	1	0.036	4*4*1.7
		2.2	0.049	
WURTH	744373 24022	2.2	0.061	4.4*4.05

Table 1. Recommend Surface Mount Inductors

INPUT CAPACITOR SELECTION

The input capacitor reduces input voltage ripple to the converter, low ESR ceramic capacitor is highly recommended. For most applications, a 10uF or 22uF capacitor is used. The input capacitor should be placed as close as possible to VIN and GND.

OUTPUT CAPACITOR SELECTION

A low ESR output capacitor is required in order to maintain low output voltage ripple. In the case of ceramic output capacitors, capacitor ESR is very small and does not contribute to the ripple, so a lower capacitance value is acceptable when ceramic capacitors are used. A 22uF ceramic output capacitor is suitable for most applications.

OUTPUT VOLTAGE PROGRAMMING

In the adjustable version, the output voltage is set by a resistive divider according to the following equation:

$$R4 = R3 \times \left(\frac{V_{out}}{0.6} - 1 \right)$$

Typically choose R3=100K and determine R4 from the following equation:

For Example, R3=100K R4=150K to set 1.5Vout

Connect a small capacitor across R4 feed forward capacitance at the FB pin for better performance.

PCB LAYOUT GUIDE

- 1, The input\output\VPB capacitors should be placed very close to the device and ground, to keep the loop resistance very low and the switching loop very small.
- 2, All ground connection must be tied together. It is desirable to maximize the PCB copper area connecting to GND/EPAD pin to achieve the best thermal and noise performance. If the board space allowed, a ground plane is highly desirable
- 3, The FB pin connection should be made as close to the load as possible so that the voltage at the load is the expected regulated value.
- 4, The FB pin and VPB connection must NOT be adjacent to the SW net on the PCB layout to avoid the noise problem
- 4, The switch node connection should be low resistance to reduce power losses.

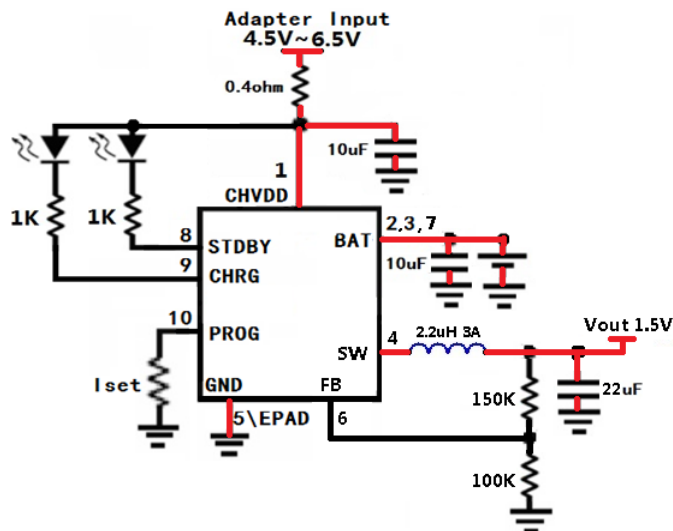

BIG CURRENT CIRCUIT(RE D LINES)

TYPICAL PERFORMANCE CHARACTERISTICS

(VIN=VEN=5V, L=2.2uH, CIN=10uF, COUT=22uF , if not mentioned)

Efficiency vs. Output Current

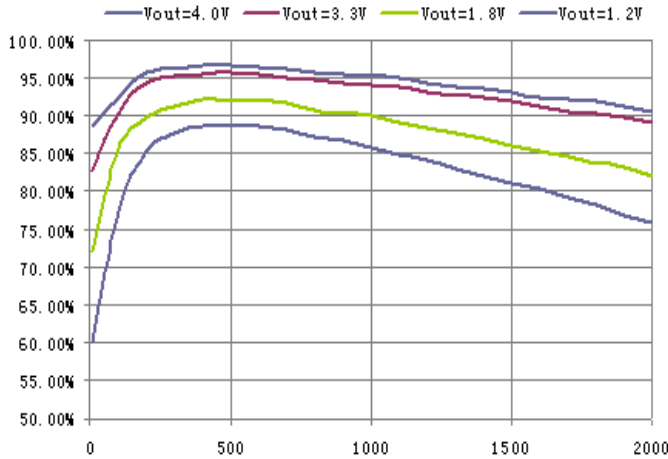

Efficiency vs. Output Current(Vout=3.3V)

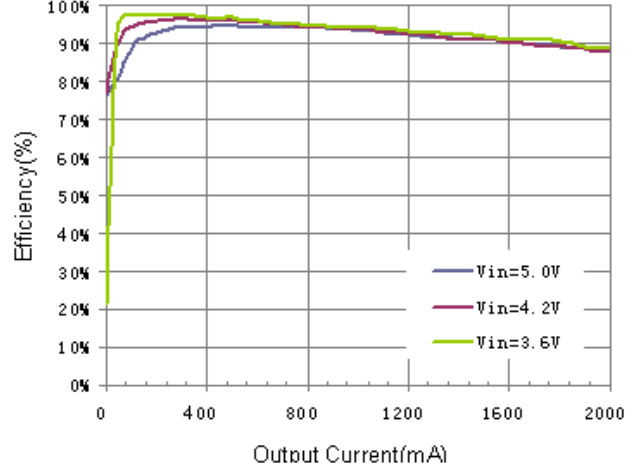

Efficiency vs. Output Current(Vout=1.8V)

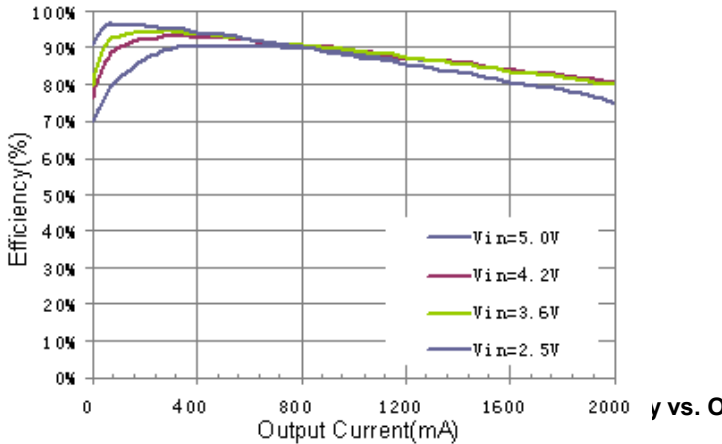

Efficiency vs. Output Current (Vout=1.2V)

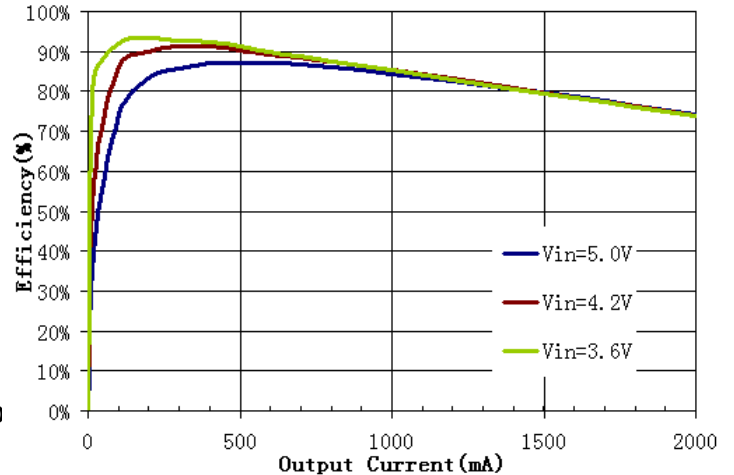

Input Current VS. Input Voltage (Vout=3.3V)

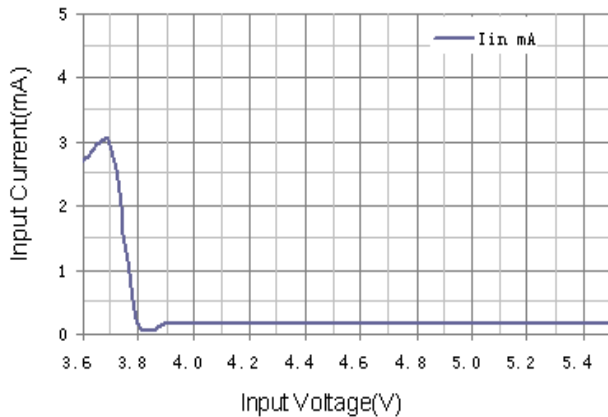

Oscillator Frequency vs. Temperature

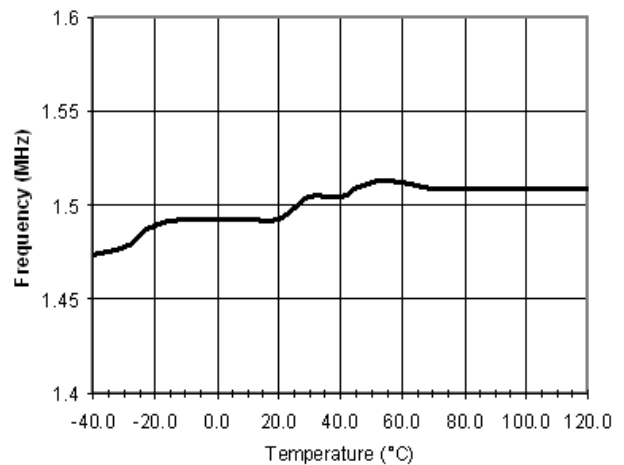

Steady State Waveform

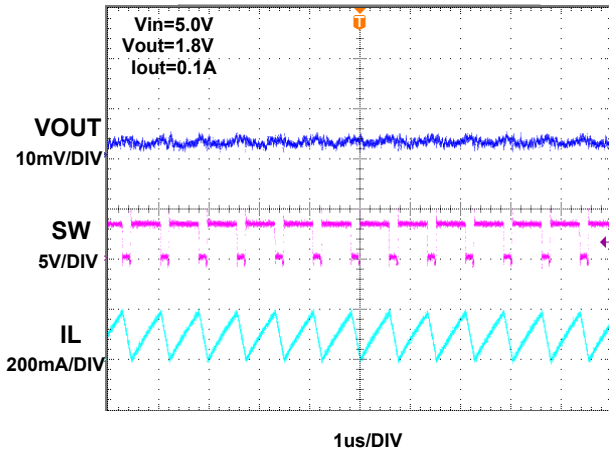

Steady State Waveform

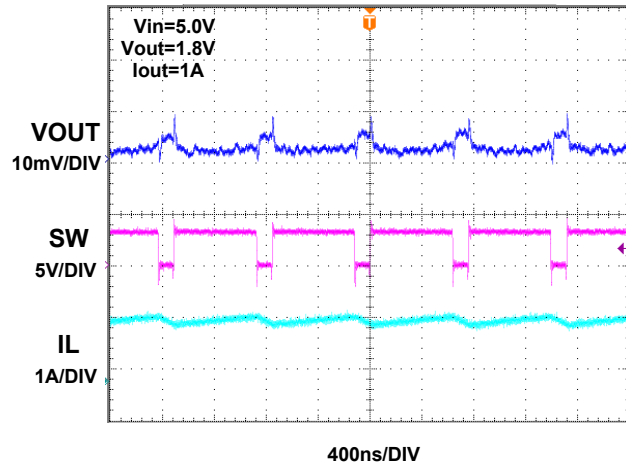

Transient Waveform(Vout=3.3V,Iout=0.15A-1.5A)

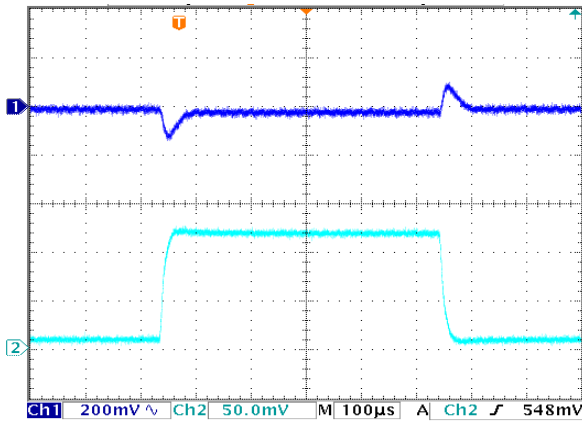

Startup through Enable Waveform

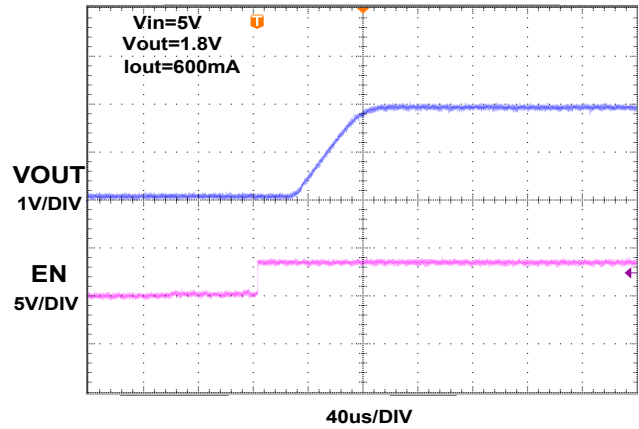

Battery charger curve

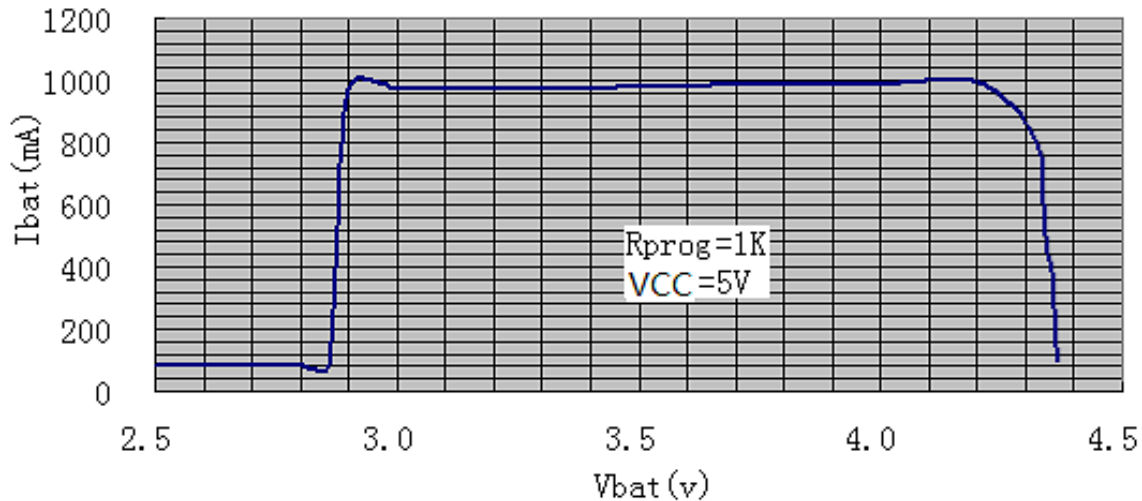

PACKAGE OUTLINE

DFN-10L 3MM X 3MM PACKAGE OUTLINE AND DIMENSIONS

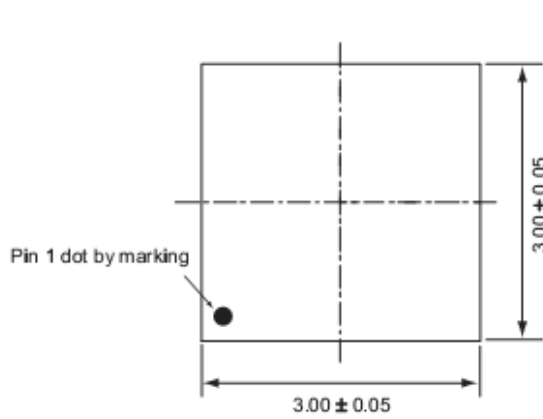

Top View

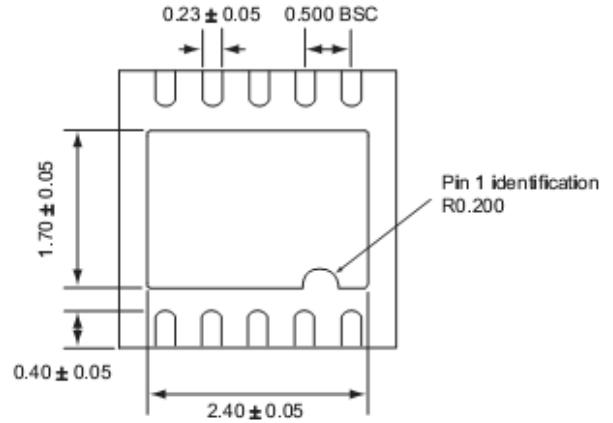

Bottom View

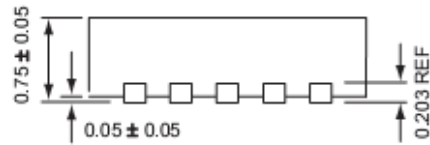

Side View