

400KHz 60V 2A Switching Current Boost / Buck-Boost / Inverting DC/DC Converter

Features

- n Wide 3.6V to 24V Input Voltage Range
- n Positive or Negative Output Voltage Programming with a Single Feedback Pin
- n Current Mode Control Provides Excellent Transient Response
- n 1.25V reference adjustable version
- n Fixed 400KHz Switching Frequency
- n Maximum 2A Switching Current
- n SW PIN Built in Over Voltage Protection
- n Excellent line and load regulation
- n EN PIN TTL shutdown capability
- n Internal Optimize Power MOSFET
- n High efficiency up to 90%
- n Built in Frequency Compensation
- n Built in Soft-Start Function
- n Built in Thermal Shutdown Function
- n Built in Current Limit Function
- n Available in SOIC-8 package

Applications

- n Automotive and Industrial Boost / Buck-Boost / Inverting Converters
- n Portable Electronic Equipment

General Description

The HM6297 regulator is a wide input range, current mode, DC/DC converter which is capable of generating either positive or negative output voltages. It can be configured as either a boost, flyback, SEPIC or inverting converter. The HM6297 built in N-channel power MOSFET and fixed frequency oscillator, current-mode architecture results in stable operation over a wide range of supply and output voltages.

The HM6297 regulator is special design for portable electronic equipment.



SOIC-8

Figure1. Package Type of HM6297

400KHz 60V 2A Switching Current Boost / Buck-Boost / Inverting DC/DC Converter

Pin Configurations

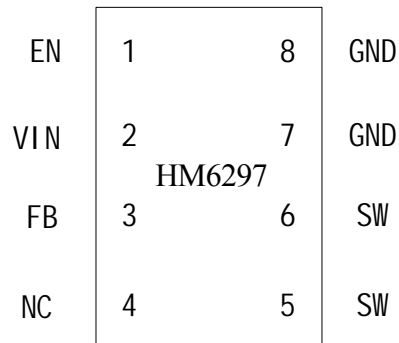

Figure2. Pin Configuration of HM6297 (Top View)

Table 1 Pin Description

Pin Number	Pin Name	Description
1	EN	Enable Pin. Drive EN pin low to turn off the device, drive it high to turn it on. Floating is default high.
2	VIN	Supply Voltage Input Pin. HM6297 operates from a 3.6V to 24V DC voltage. Bypass Vin to GND with a suitably large capacitor to eliminate noise on the input.
3	FB	Feedback Pin (FB). The feedback threshold voltage is 1.25V.
4	NC	No Connected.
5,6	SW	Power Switch Output Pin (SW). Output is the switch node that supplies power to the output.
7,8	GND	Ground Pin.

400KHz 60V 2A Switching Current Boost / Buck-Boost / Inverting DC/DC Converter

Function Block

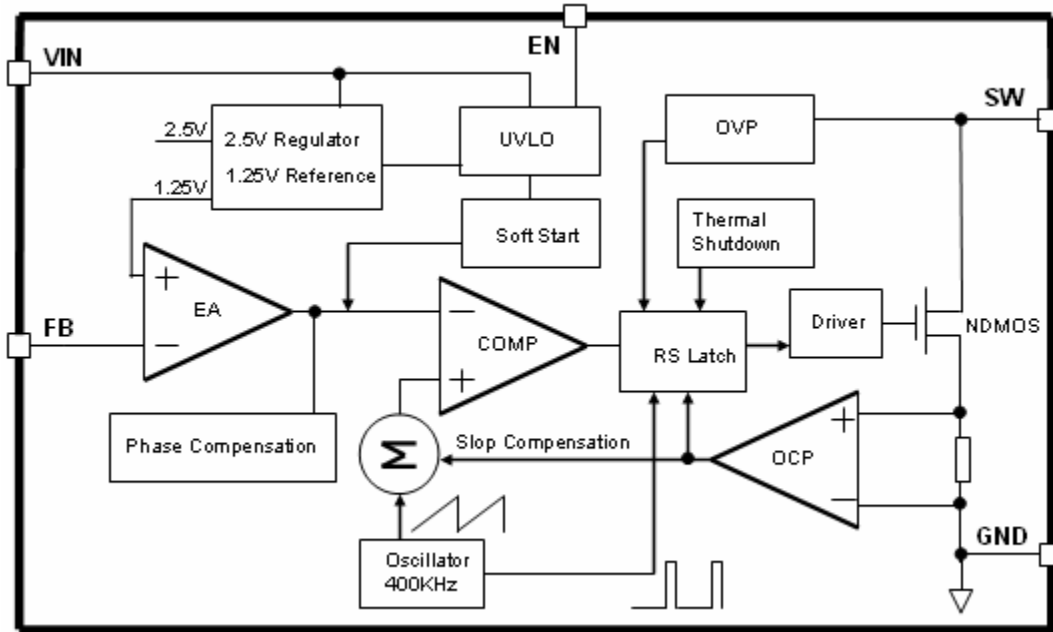

Figure3. Function Block Diagram of HM6297

Typical Application Circuit

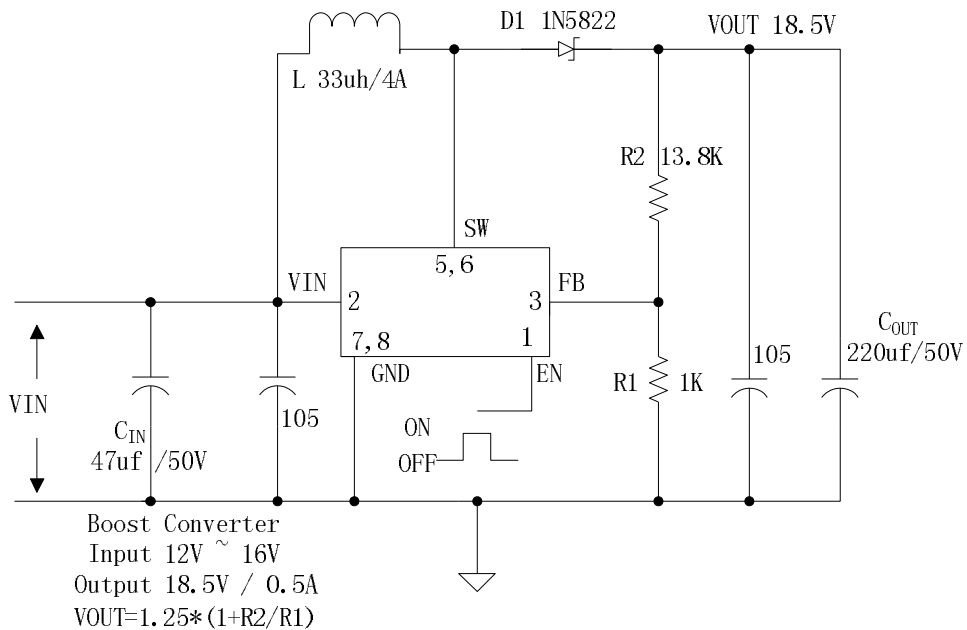

Figure4. HM6297 Typical Application Circuit (Boost Converter)

400KHz 60V 2A Switching Current Boost / Buck-Boost / Inverting DC/DC Converter

Ordering Information

Package	Temperature Range	Part Number	Marking ID	Packing Type
		Lead Free	Lead Free	
		HM6297	HM6297	Tube
		HM6297	HM6297	Tape & Reel

Absolute Maximum Ratings (Note1)

Parameter	Symbol	Value	Unit
Input Voltage	V _{in}	-0.3 to 26	V
Feedback Pin Voltage	V _{FB}	-0.3 to V _{in}	V
EN Pin Voltage	V _{EN}	-0.3 to V _{in}	V
Output Switch Pin Voltage	V _{Output}	-0.3 to 60	V
Power Dissipation	P _D	Internally limited	mW
Thermal Resistance (SOP-8L) (Junction to Ambient, No Heatsink, Free Air)	R _{JA}	100	°C/W
Operating Junction Temperature	T _J	-40 to 125	°C
Storage Temperature	T _{STG}	-65 to 150	°C
Lead Temperature (Soldering, 10 sec)	T _{LEAD}	260	°C
ESD (HBM)		>2000	V

Note1: Stresses greater than those listed under Maximum Ratings may cause permanent damage to the device. This is a stress rating only and functional operation of the device at these or any other conditions above those indicated in the operation is not implied. Exposure to absolute maximum rating conditions for extended periods may affect reliability.

400KHz 60V 2A Switching Current Boost / Buck-Boost / Inverting DC/DC Converter

J O 84; 9 Electrical Characteristics

$T_a = 25^\circ\text{C}$; unless otherwise specified.

Symbol	Parameter	Test Condition	Min.	Typ.	Max.	Unit
<i>System parameters test circuit figure4</i>						
VFB	Feedback Voltage	$V_{in} = 12\text{V to } 16\text{V}, V_{out}=18\text{V}$ $I_{load}=0.1\text{A to } 0.5\text{A}$	1.213	1.25	1.287	V
Efficiency	η	$V_{in}=12\text{V}, V_{out}=18.5\text{V}$ $I_{out}=0.5\text{A}$	-	90	-	%

Electrical Characteristics (DC Parameters)

$V_{in} = 12\text{V}$, $GND=0\text{V}$, V_{in} & GND parallel connect a $220\mu\text{f}/50\text{V}$ capacitor; $I_{out}=0.5\text{A}$, $T_a = 25^\circ\text{C}$; the others floating unless otherwise specified.

Parameters	Symbol	Test Condition	Min.	Typ.	Max.	Unit
Input operation voltage	V_{in}		3.6		24	V
Shutdown Supply Current	I_{STBY}	$V_{EN}=0\text{V}$		70	100	μA
Quiescent Supply Current	I_q	$V_{EN} = 2\text{V},$ $V_{FB} = V_{in}$		2.5	5	mA
Oscillator Frequency	F_{osc}		320	400	480	Khz
Switch Current Limit	I_L	$V_{FB} = 0$		2		A
Output Power NMOS	R_{dson}	$V_{in}=12\text{V},$ $I_{sw}=2\text{A}$		110	120	mohm
EN Pin Threshold	V_{EN}	High (Regulator ON) Low (Regulator OFF)		1.4 0.8		V
EN Pin Input Leakage Current	I_H	$V_{EN} = 2\text{V (ON)}$		3	10	μA
	I_L	$V_{EN} = 0\text{V (OFF)}$		3	10	μA
Max. Duty Cycle	D_{MAX}	$V_{FB}=0\text{V}$		90		%

400KHz 60V 2A Switching Current Boost / Buck-Boost / Inverting DC/DC Converter

Schottky Diode Selection Table

Current	Surface Mount	Through Hole	VR (The same as system maximum input voltage)				
			20V	30V	40V	50V	60V
1A		✓	1N5817	1N5818	1N5819		
3A		✓	1N5820	1N5821	1N5822		
		✓	MBR320	MBR330	MBR340	MBR350	MBR360
	✓		SK32	SK33	SK34	SK35	SK36
	✓			30WQ03	30WQ04	30WQ05	
		✓		31DQ03	31DQ04	31DQ05	
		✓	SR302	SR303	SR304	SR305	SR306

Typical System Application – Boost (Output 18.5V/0.5A)

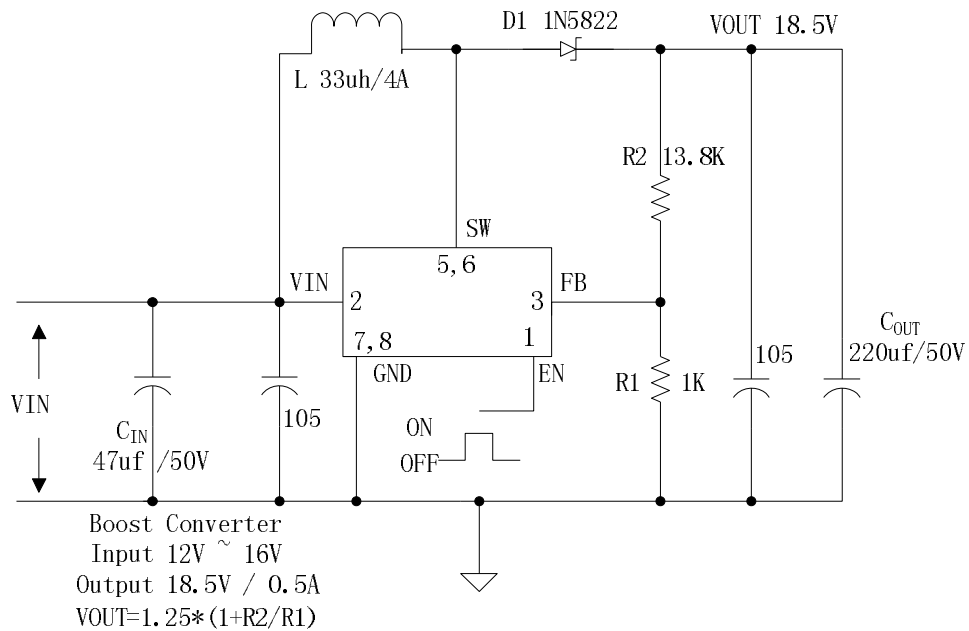

Figure5. HM6297 Typical System Application (Boost Converter)

400KHz 60V 2A Switching Current Boost / Buck-Boost / Inverting DC/DC Converter

Typical System Application – SEPIC Buck-Boost (Input 10V~18V, Output 12V/0.5A)

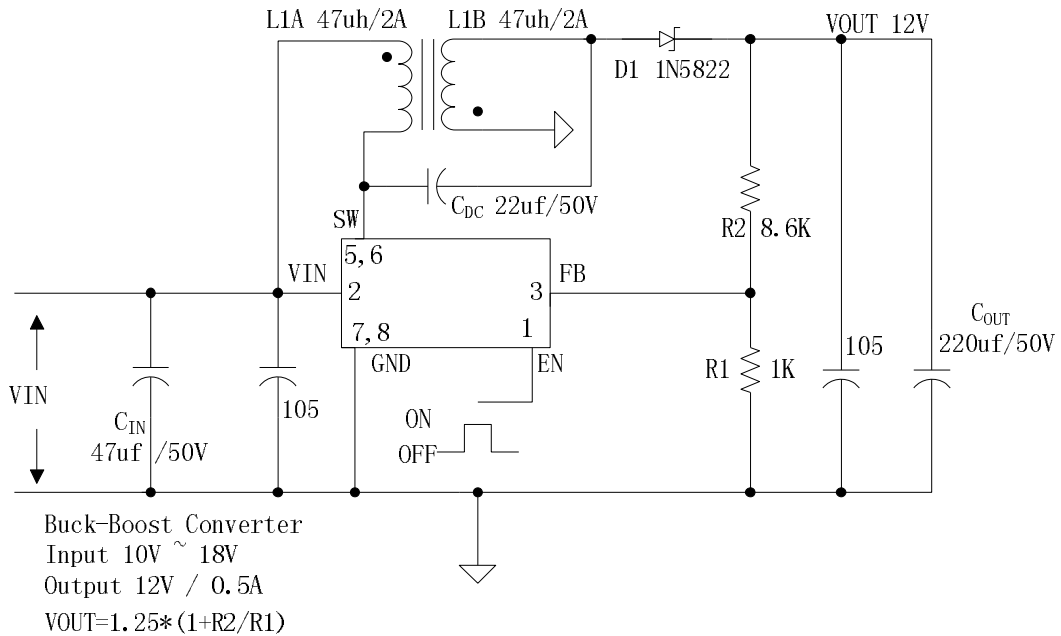

Figure6. HM6297 Typical System Application (SEPIC Buck-Boost Converter)

Typical System Application for Inverting Converter

– SEPIC Inverting Topology (Input 10V~18V, Output + -12V/0.6A)

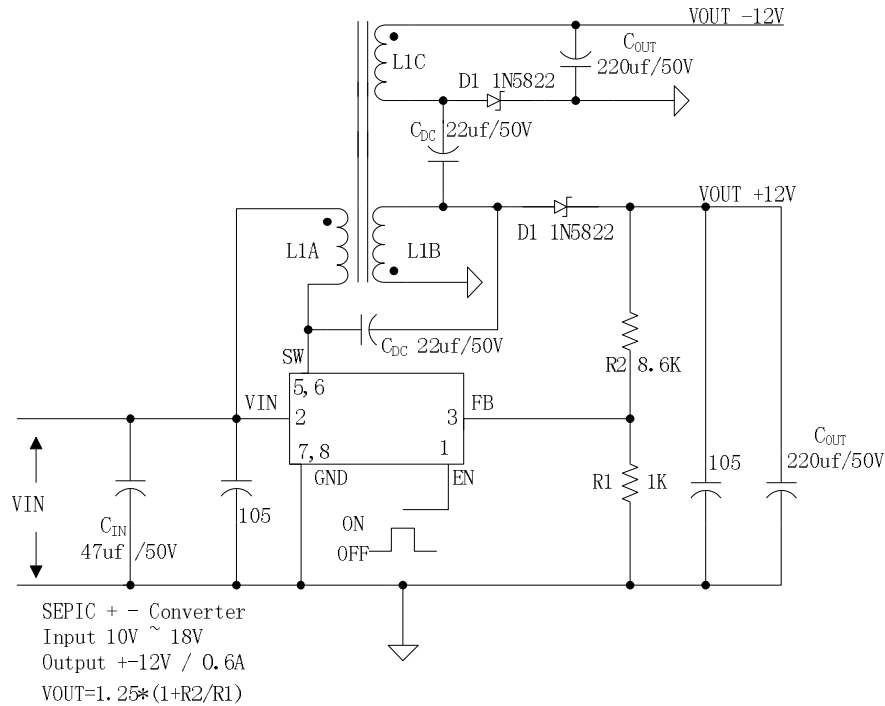

Figure7. HM6297 Typical System Application (SEPIC Inverting Converter)

400KHz 60V 2A Switching Current Boost / Buck-Boost / Inverting DC/DC Converter

Package Information

SOP8 Package Mechanical Dimensions

